

SOMERSET COUNTY PUBLIC WORKS HANDBOOK DETAILS

SOMERSET COUNTY
DEPARTMENT OF PUBLIC WORKS



ENGINEERING DIVISION



PAUL L. MCCALL
DIRECTOR OF PUBLIC WORKS

MATTHEW D. LOPER
COUNTY ENGINEER

2011

SOMERSET COUNTY
ACCEPTANCE STAMP

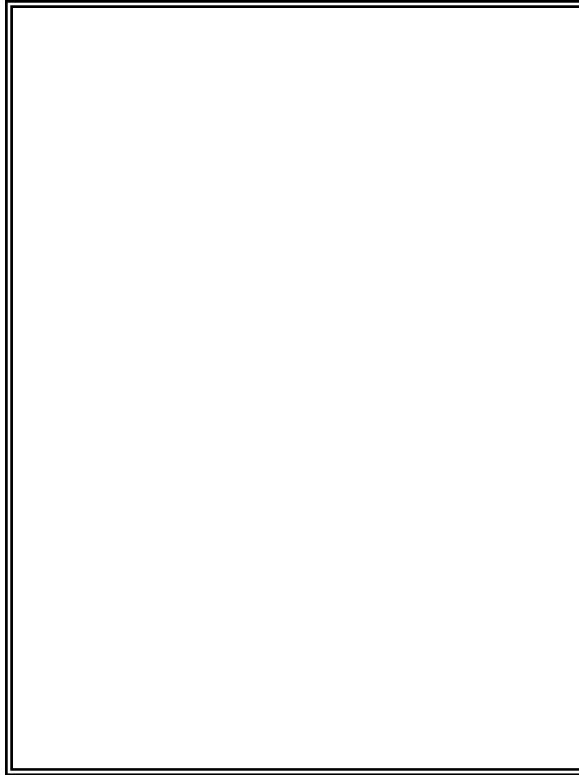

THESE PLANS ARE NOT ACCEPTED FOR
CONSTRUCTION UNLESS THIS BLOCK IS STAMPED
"ACCEPTED AS SUBMITTED" BY A STAFF MEMBER OF
THE SOMERSET COUNTY ENGINEERING DIVISION.
BIDS FOR CONSTRUCTION SHOULD NOT BE BASED ON
THESE PLANS UNTIL THE PLANS ARE ACCEPTED BY
THE COUNTY.

ACCEPTANCE OF THESE PLANS EXPIRE TWO (2)
YEARS FROM THE STAMPED DATE.

NOTE: THIS BLOCK SHALL BE A MINIMUM OF 4" X 3"

STANDARD CONSTRUCTION NOTES FOR ROAD IMPROVEMENTS

1. Prior to the initiation of any excavation or construction within any street, road, or right of way under the jurisdiction of the Somerset County Board of Chosen Freeholders, a Somerset County Road Opening Permit shall be obtained from the Office of the County Engineer.
2. The Office of the County Engineer is to be notified seventy-two (72) hours in advance of commencement of construction of any improvements under the jurisdiction of the County of Somerset. Grade construction sheets will be submitted at this time. These grade construction sheets are to be signed and sealed by a professional land surveyor.
3. As indicated in the "Manual on Uniform Traffic Control Devices," proper and sufficient construction warning signs are to be provided and maintained by contractors performing construction work along County roads. Said signs are to be maintained until construction is completed and approved by the appropriate County inspection personnel.
4. All improvements under the jurisdiction of the County of Somerset are to be constructed in accordance with Somerset County Specifications.
5. All mailboxes, located within the construction improvements in the County R.O.W. will be reset in accordance with the owner of the mailbox and the postmaster.
6. Information monuments, markers, disks, rivets of the National Geodetic Control Survey may be obtained from the New Jersey Department of Transportation, Geodetic Division, 1035 Parkway Avenue, Trenton, NJ, telephone #(609) 530-5641; or the Somerset County Engineering Division, telephone #(908) 231-7024, ext. 7512.
7. The New Jersey Geodetic Control Survey, at the above address, is to be notified two (2) weeks in advance of commencement of construction of any improvements in order to preserve the resetting of existing monuments, or installation of new monuments if required by the County.

Prepared by: Somerset County Department of Public Works

PC41A

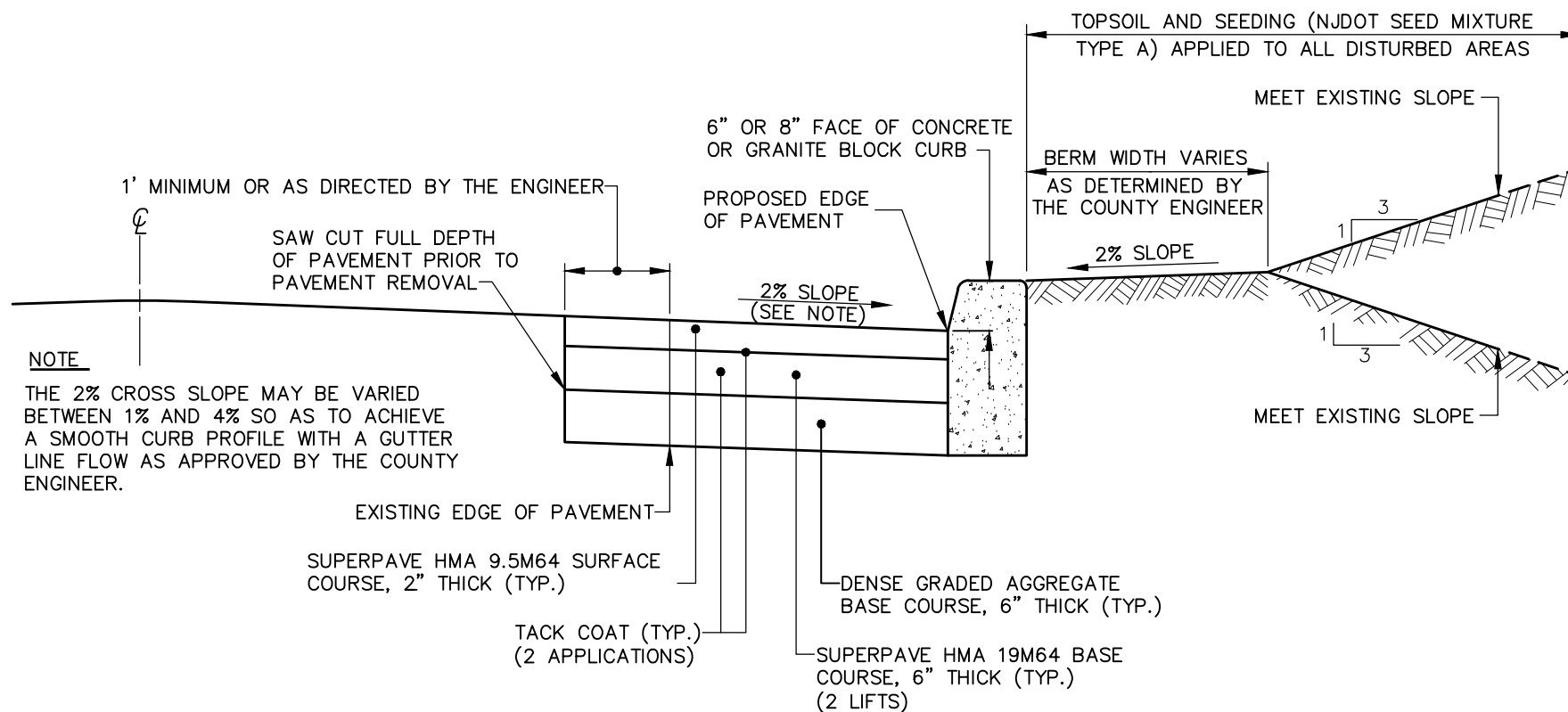

ROAD-WIDENING WITH CURB

N.T.S.

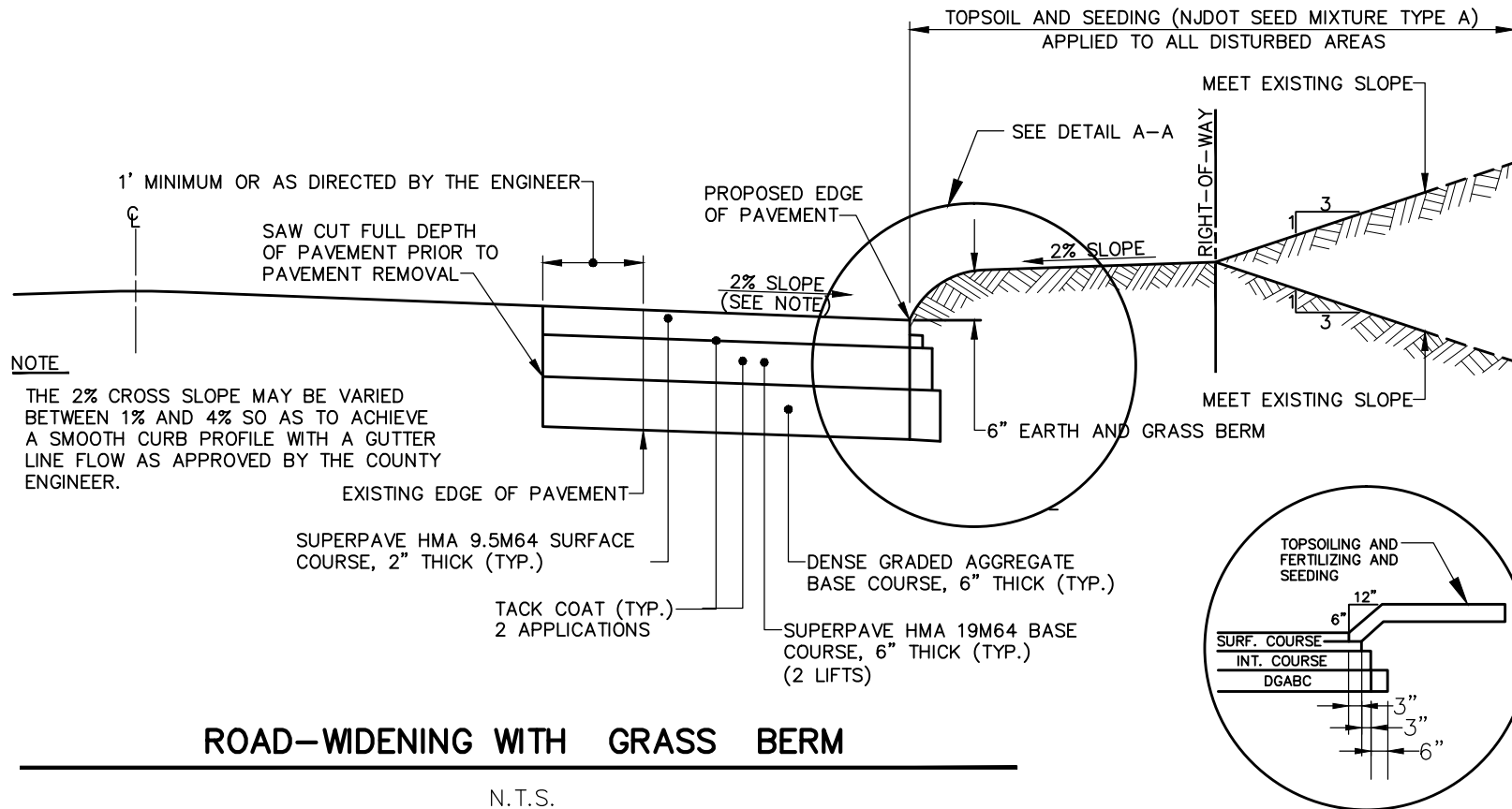

ROAD-WIDENING WITH GRASS BERM

N.T.S.

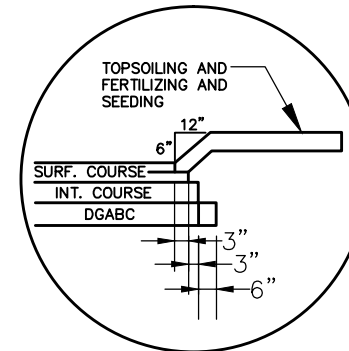

DETAIL A-A

EARTH BERM AND PAVEMENT STEPPING TREATMENT DETAIL

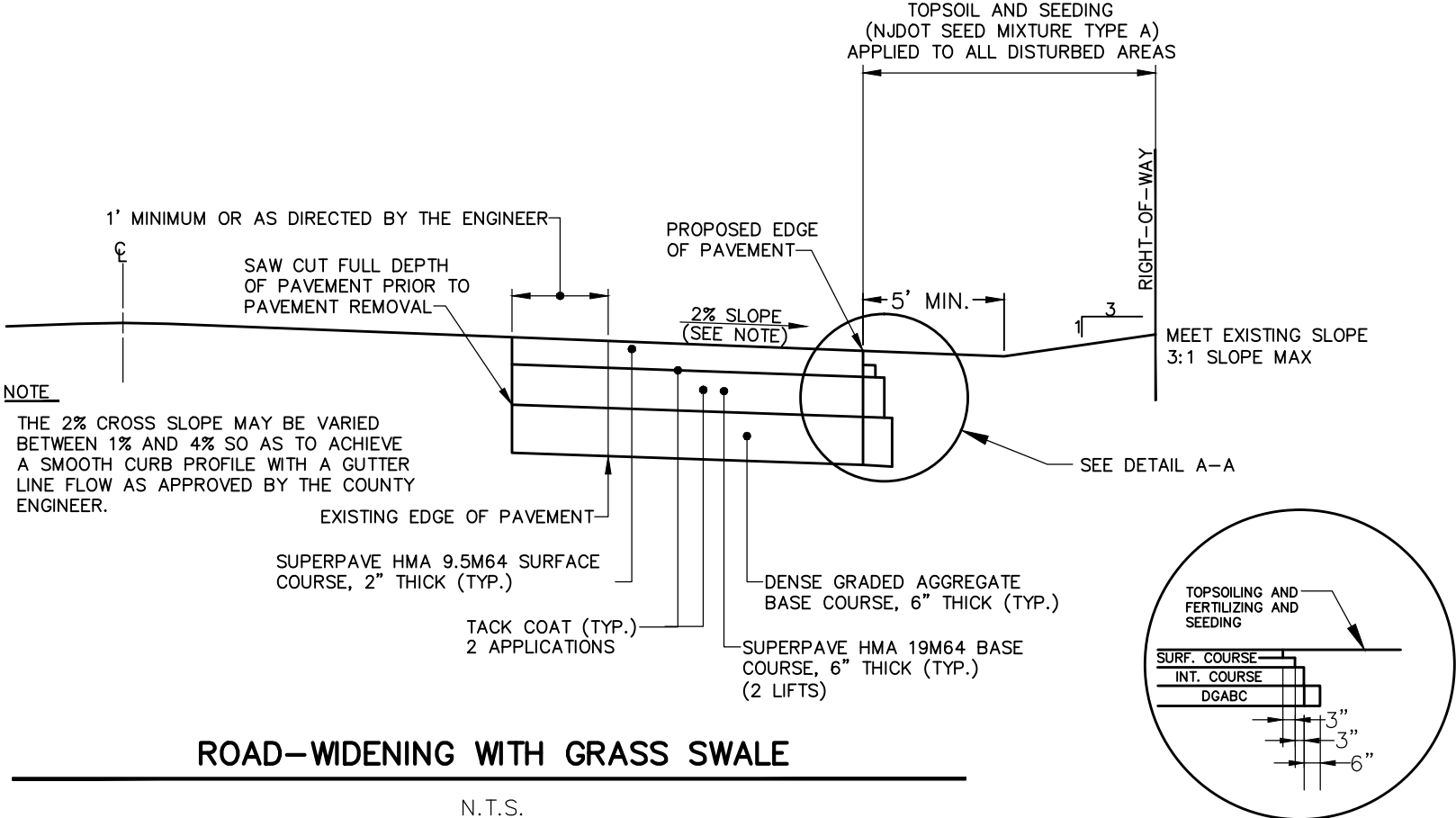

ROAD-WIDENING WITH GRASS SWALE

N.T.S.

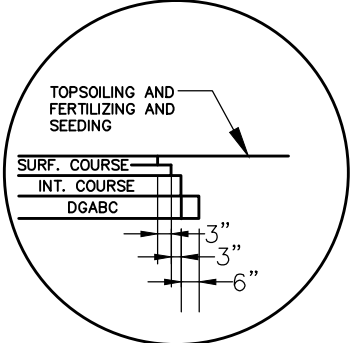

DETAIL A-A

EARTH BERM AND PAVEMENT STEPPING TREATMENT DETAIL

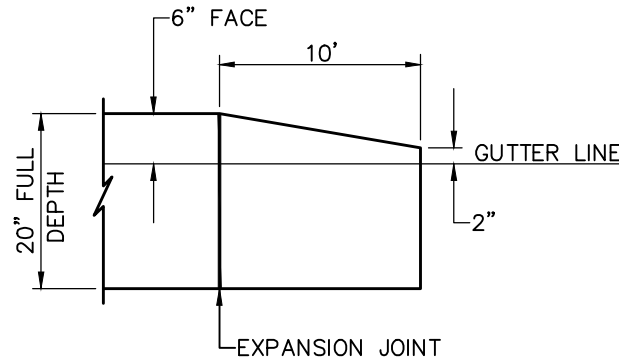
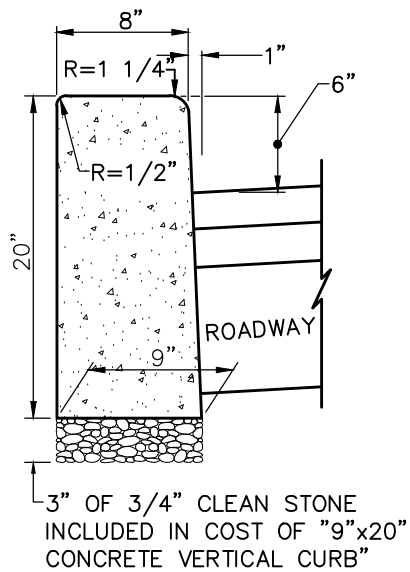

CURBING END SECTION

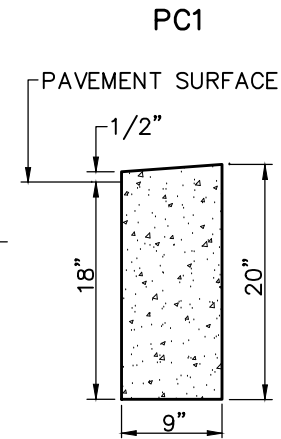

SECTION A-A

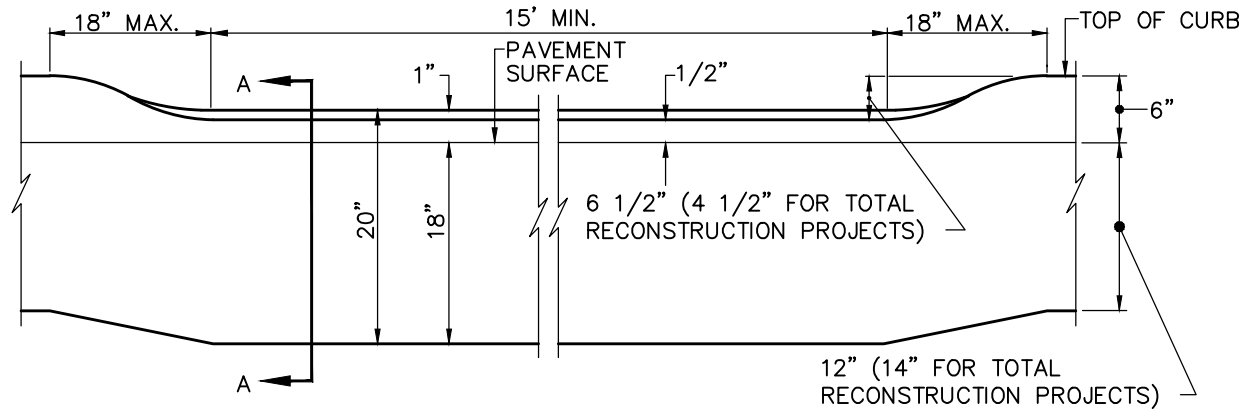

METHOD OF DEPRESSING CURB AT DRIVEWAYS

NOTES

1. EXPANSION JOINTS ALTERNATE EVERY 10 FEET WITH CONSTRUCTION JOINTS. EXPANSION JOINTS SHALL BE FILLED WITH PREFORMED, BITUMINOUS-IMPREGNATED FIBER JOINT FILLER RECESSED 1/4" FROM THE FACE AND TOP OF THE CURB. SUCH JOINTS SHALL BE INSTALLED BETWEEN CURB AND INLET HEADS.
2. ALL JOINTS SHALL EXTEND THE FULL 20" DEPTH OF THE CURB.
3. THE CURB SHALL BE COMPOSED OF CLASS "B" CONCRETE.

9" x 20" CONCRETE CURB

N.T.S.

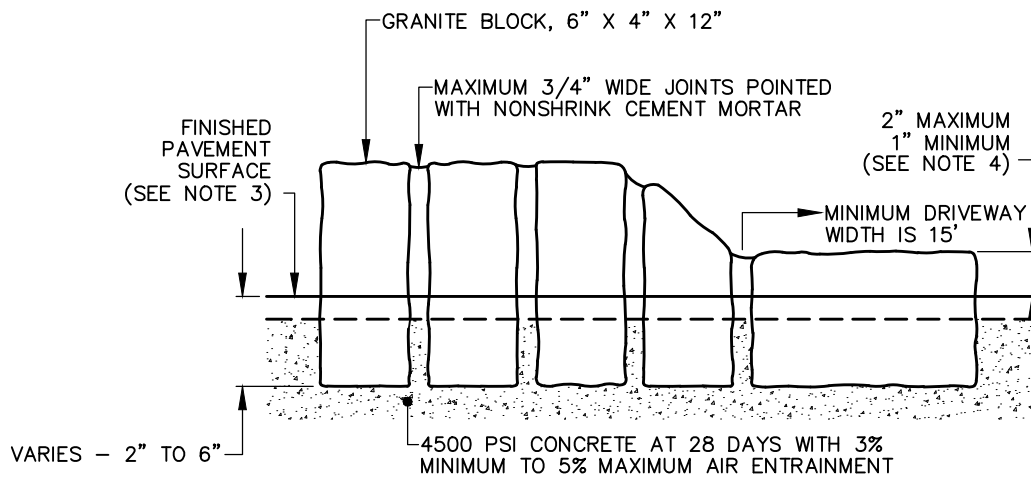
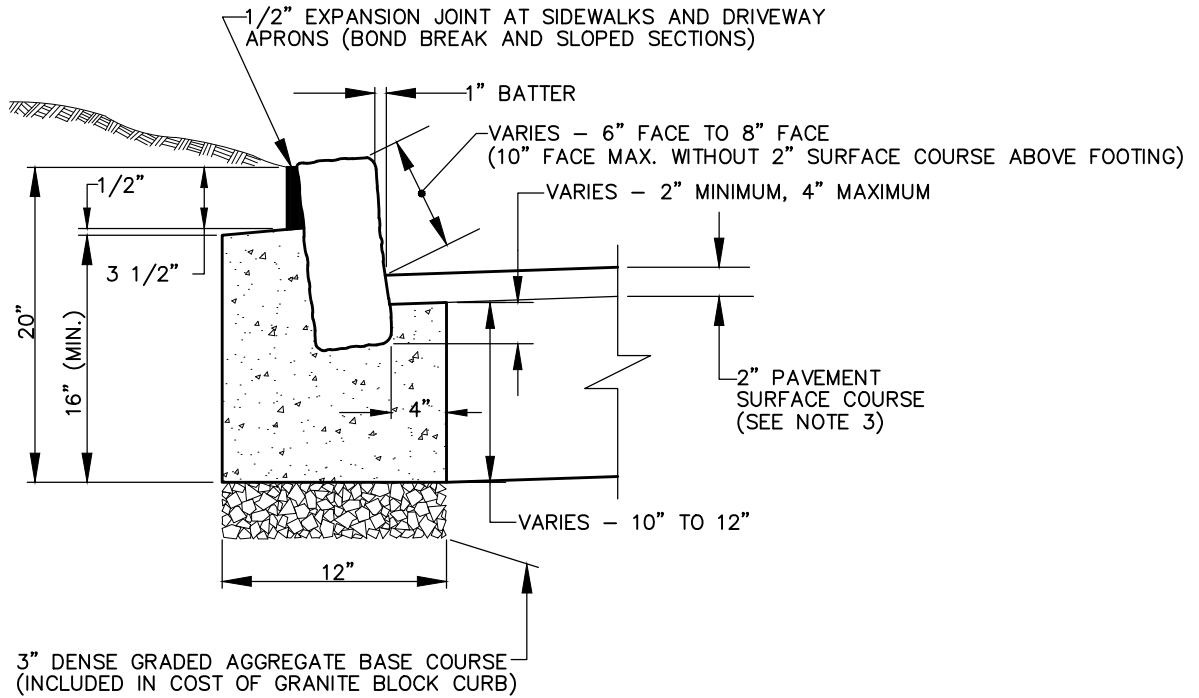

GRANITE BLOCK CURB

N.T.S.

NOTES:

1. THIS DETAIL SHALL BE USED FOR ALL FULL HEIGHT AND DRIVEWAY DEPRESSED GRANITE BLOCK CURBING WITHIN THE COUNTY'S RIGHT-OF-WAY.
2. BOTTOM OF GRANITE BLOCK CURB MUST BE EMBEDDED A MINIMUM OF 2" AND A MAXIMUM OF 4" INTO THE CONCRETE FOOTING.
3. FOR INTERIM CONDITIONS, CONCRETE FOOTING EDGE SHALL NOT BE LEFT EXPOSED ABOVE TOP PAVING COURSE. TOP INTERIM PAVING COURSE SHALL BE INSTALLED FLUSH OR ABOVE CONCRETE FOOTING.
4. CURB DEPRESSIONS FOR DRIVEWAYS MUST HAVE BETWEEN A 1" AND 2" LIP TO MAINTAIN GUTTER LINE STORMWATER CONVEYANCE.

NOTES

1/2" PREFORMED EXPANSION JOINT FILLER BITUMINOUS TYPE, TO BE INSTALLED BETWEEN THE CURB AND CONCRETE PAVEMENT OR CONCRETE BASE COURSE.

TRANSVERSE JOINTS 1/2" WIDE SHALL BE INSTALLED 20' APART IN THE CURB AND SHALL BE FILLED WITH PREFORMED BITUMINOUS IMPREGNATED FIBER JOINT FILLER RECESSED 1/4" IN FROM FRONT FACE AND TOP OF CURB.

EXPANSION JOINTS THRU AND ADJACENT TO THE CURB SHALL BE INCLUDED IN THE UNIT PRICE BID FOR CURBS.

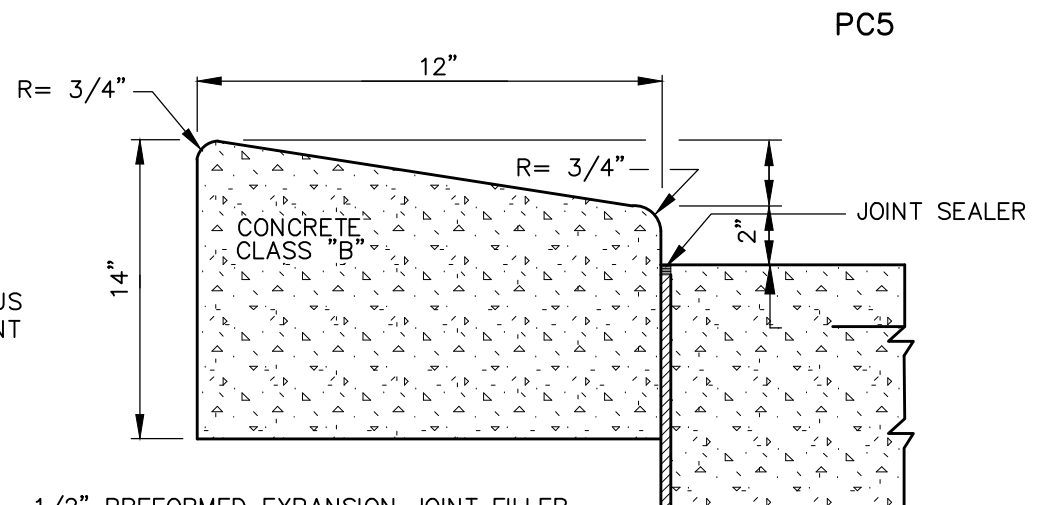

1/2" PREFORMED EXPANSION JOINT FILLER
DEPTH OF FILLER STRIP EQUALS PAVEMENT
THICKNESS LESS 1/2", TO BE INSTALLED
BETWEEN CURB AND CONCRETE PAVEMENT
OR BASE COURSE.

12" X 13" CONCRETE SLOPING CURB

NTS

PC4B

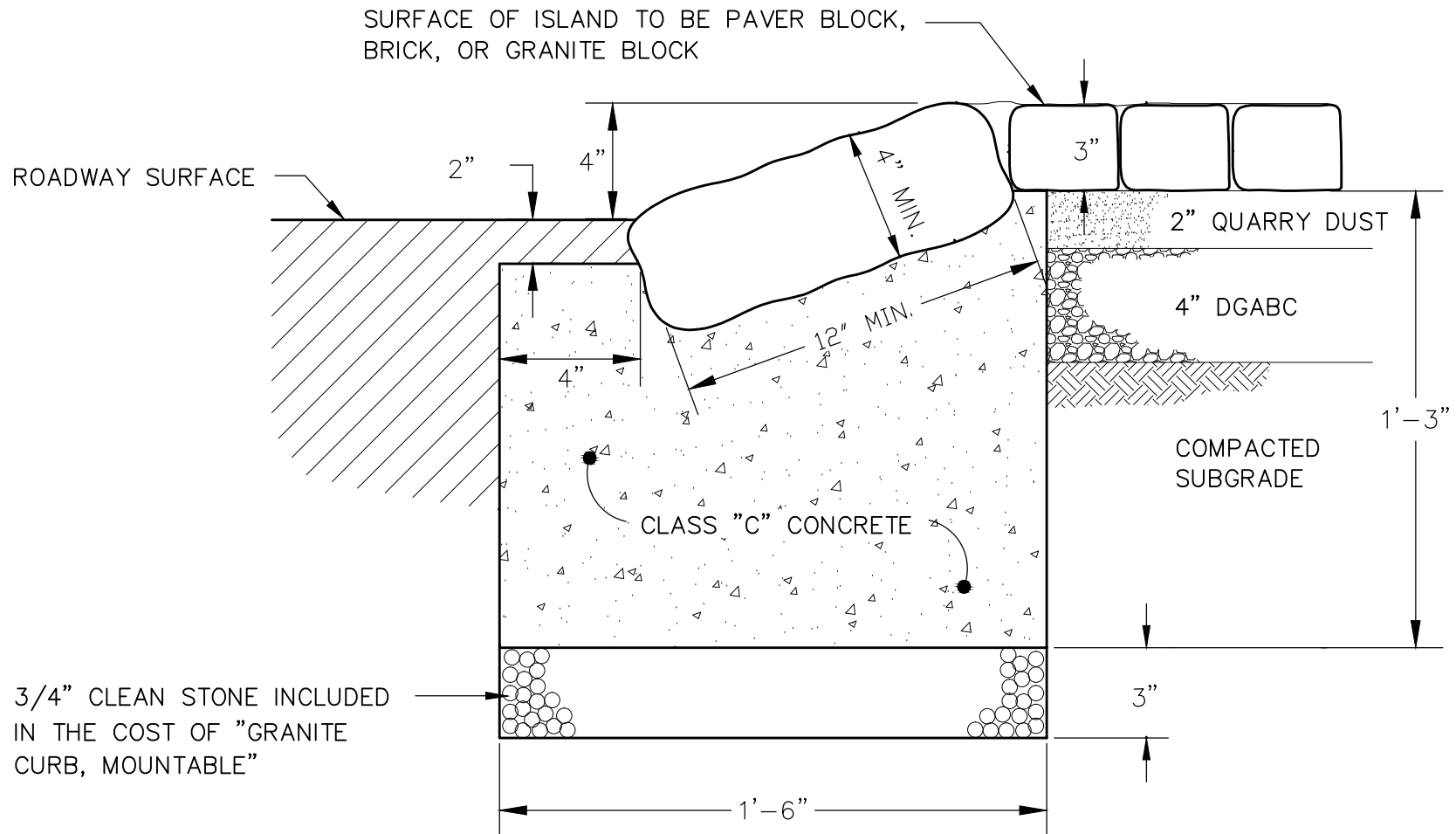

GRANITE CURB, MOUNTABLE ISLAND

PC32

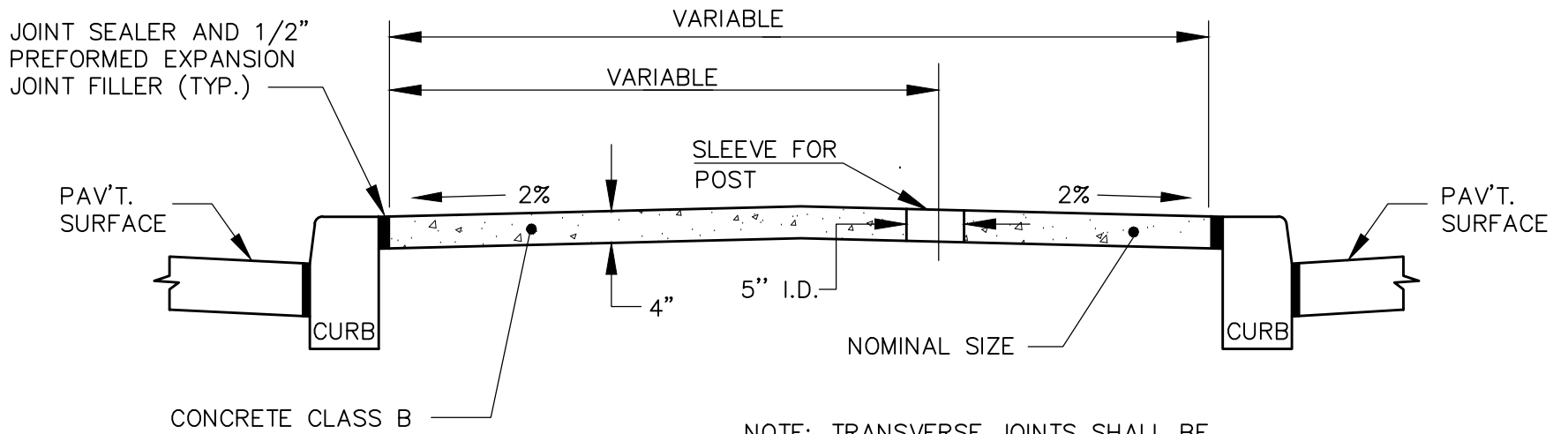

CONCRETE ISLAND, 4" THICK

N.T.S.

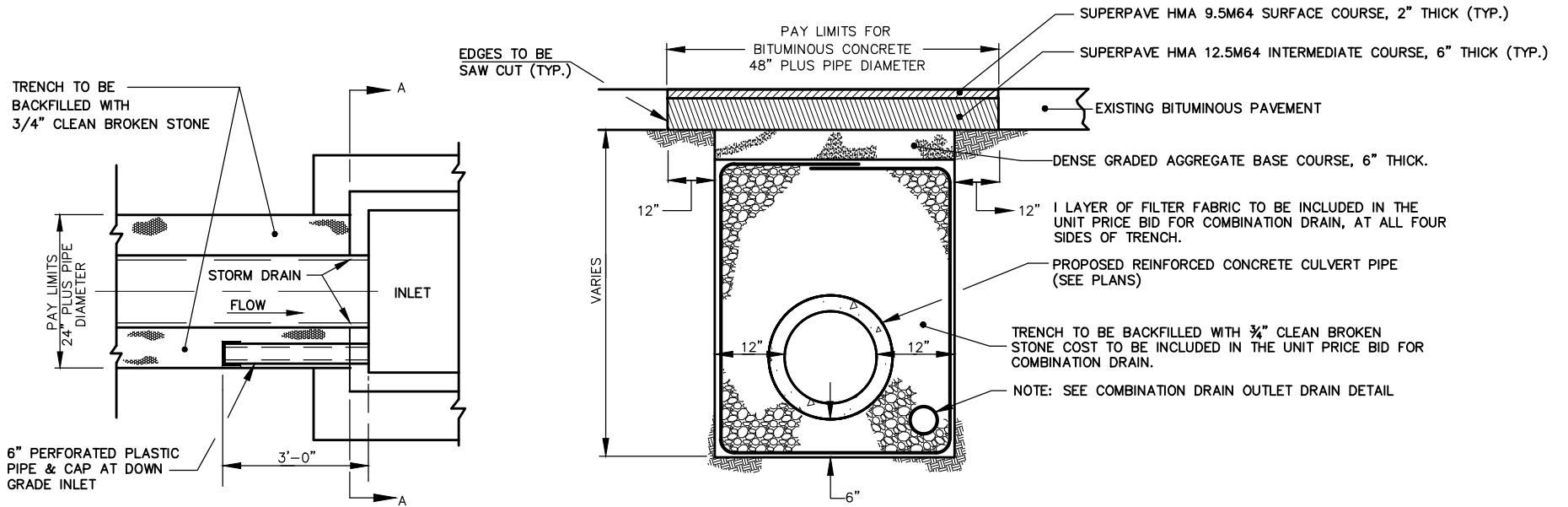

COMBINATION DRAIN

N.T.S.

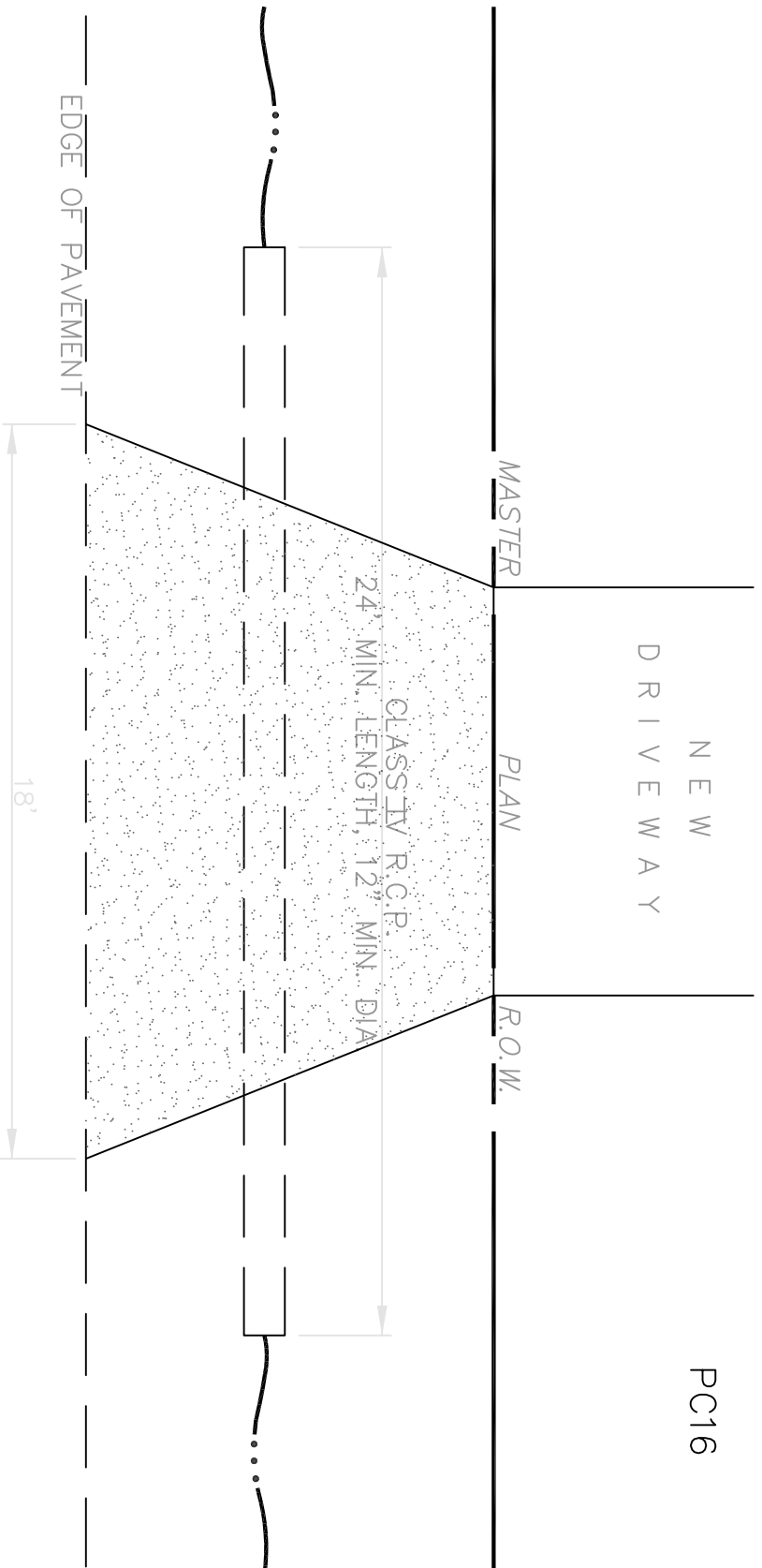

NOTES

1. THE PAVED DRIVEWAY APRON (SHADED AREA ABOVE) SHALL BE COMPOSED OF BITUMINOUS CONCRETE SURFACE COURSE, 1 1/2" THICK, AND BITUMINOUS STABILIZED BASE COURSE, 3" THICK. THE APRON SHALL BE A MINIMUM OF 10' FROM THE EDGE OF THE PAVEMENT, OR TO THE MASTER PLAN R.O.W. PROFILE SHALL NOT EXCEED 6% WITHIN COUNTY R.O.W.
2. A ROAD-OPENING PERMIT IS REQUIRED BEFORE CONSTRUCTION COMMENCES IN THE COUNTY R.O.W.
3. THE COMPLETED DRIVEWAY MUST NOT IMPEDE THE FLOW OF STORMWATER ALONG THE COUNTY ROAD. IF NECESSARY, A PIPE IS TO BE INSTALLED AS ILLUSTRATED ABOVE. IF A PIPE IS NOT NECESSARY, THE APRON SHALL BE CONSTRUCTED TO CONVEY FLOWS OVER IT.

DRIVEWAY APRON

N.T.S.

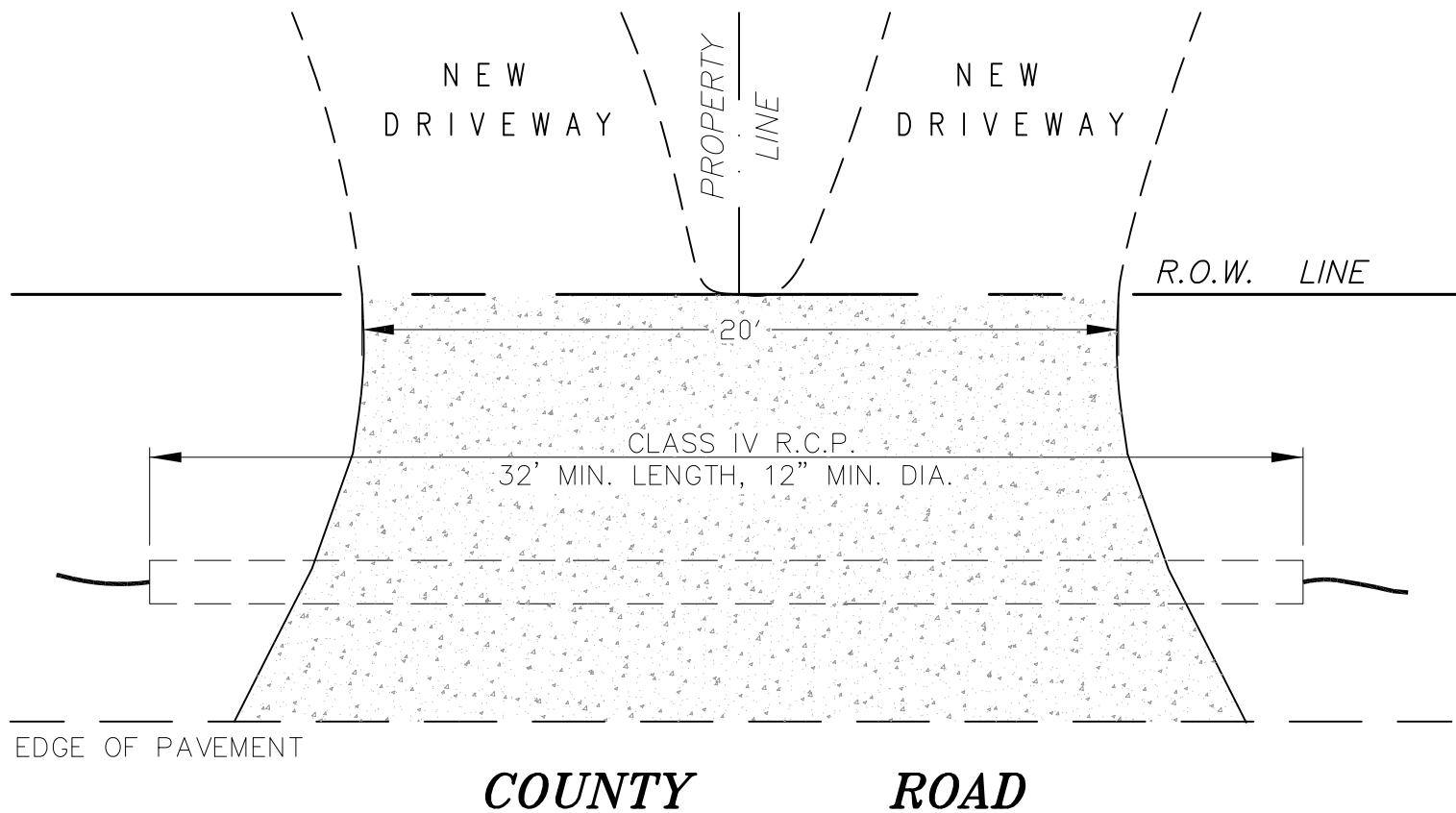

NOTES

1. THE ENTIRE SHARED PORTION OF THE DRIVEWAY IS IN THE COUNTY RIGHT-OF-WAY.
2. THE PAVED DRIVEWAY APRON (SHADED AREA ABOVE) SHALL BE COMPOSED OF BITUMINOUS CONCRETE SURFACE COURSE, 1 1/2" THICK, AND BITUMINOUS STABILIZED BASE COURSE, 4" THICK. THE APRON SHALL EXTEND TO THE MASTER PLAN RIGHT-OF-WAY.
3. A ROAD-OPENING PERMIT IS REQUIRED BEFORE CONSTRUCTION COMMENCES IN THE COUNTY R.O.W.
4. THE COMPLETED DRIVEWAY MUST NOT IMPEDE THE FLOW OF STORMWATER ALONG THE COUNTY ROAD. IF NECESSARY, A PIPE IS TO BE INSTALLED AS ILLUSTRATED ABOVE. IF A PIPE IS NOT NECESSARY, THE APRON SHALL BE CONSTRUCTED TO CONVEY FLOWS OVER IT.

SHARED DRIVEWAY APRON

N.T.S.

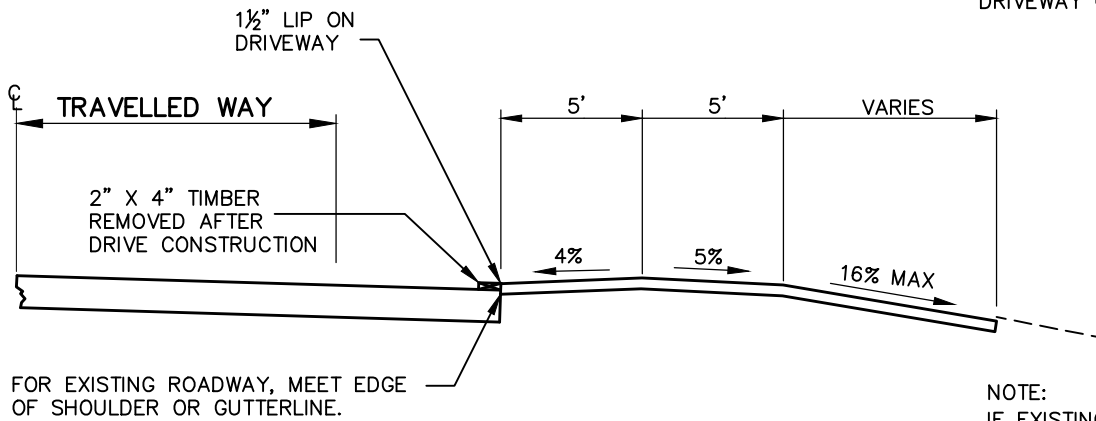
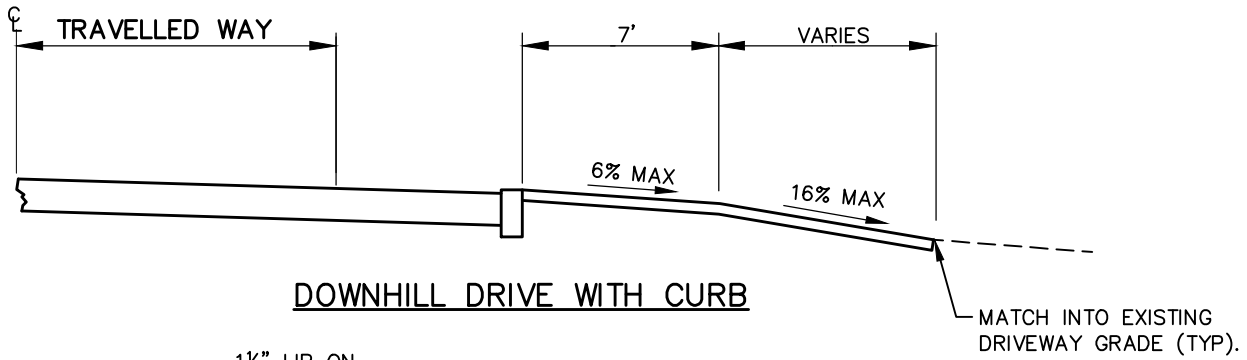

NOTE:
 IF EXISTING DRIVEWAY IS STONE, IT IS TO RECEIVE AN HMA APRON, 7' MIN. FROM EDGE OF ROADWAY. PAID UNDER ITEM "HMA DRIVEWAY, 4 1/2" THICK". DRIVEWAY STONE PAID UNDER ITEM, "STONE DRIVEWAY, 4" THICK".

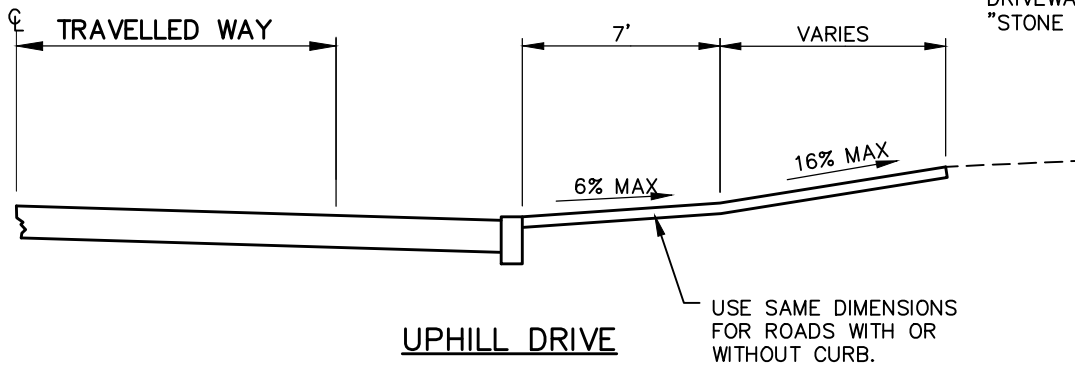

DRIVEWAY PROFILES

N.T.S.

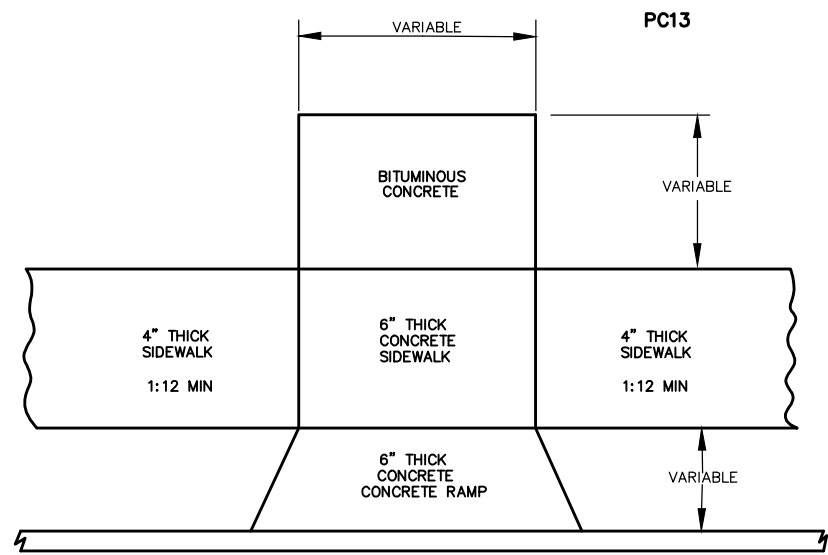
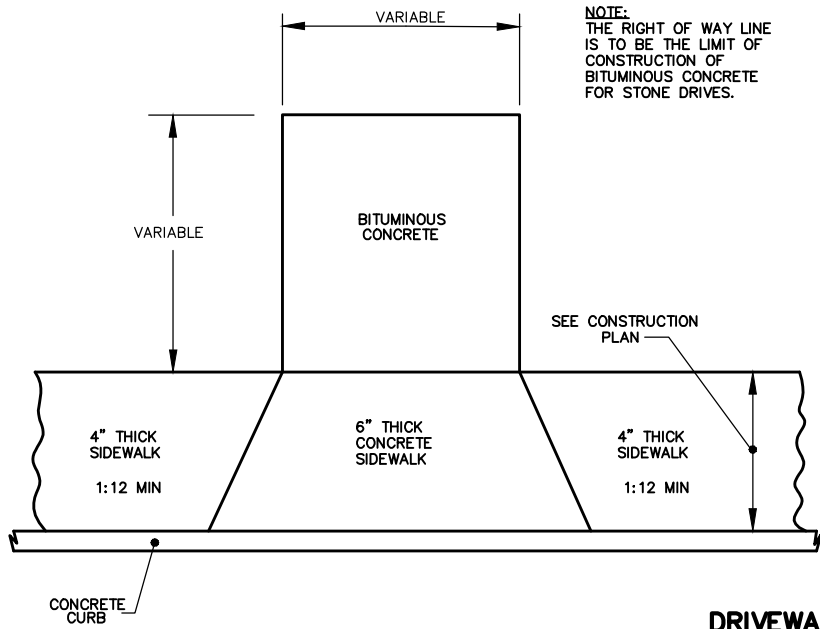

DRIVEWAYS WITH SIDEWALKS

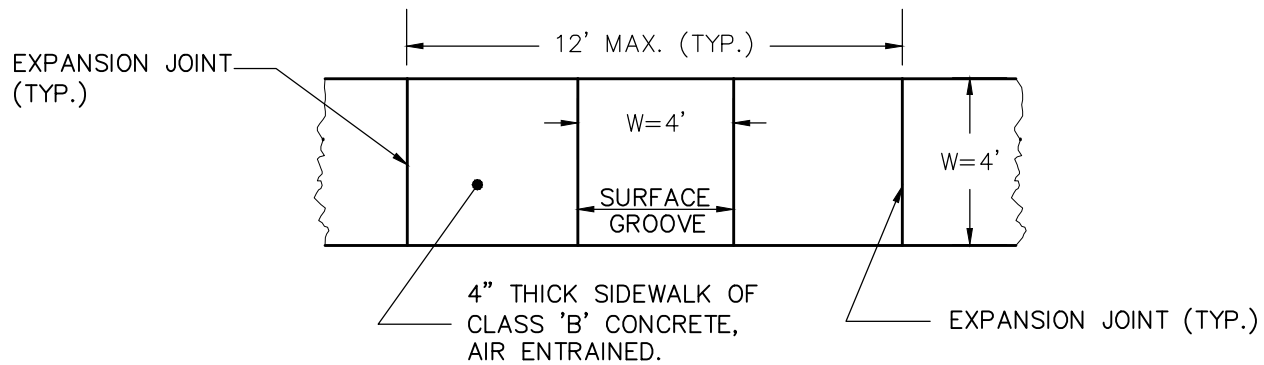

JOINT PLACEMENT DETAIL

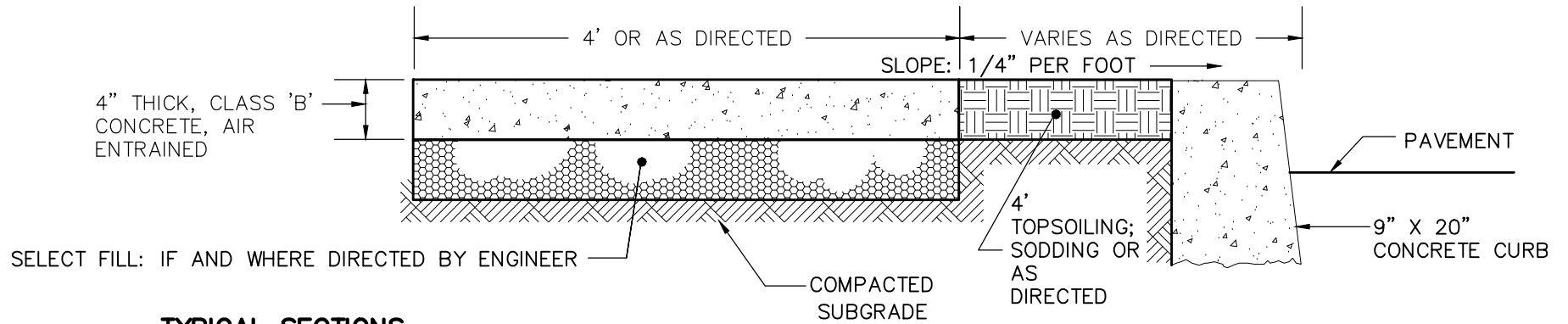

TYPICAL SECTIONS

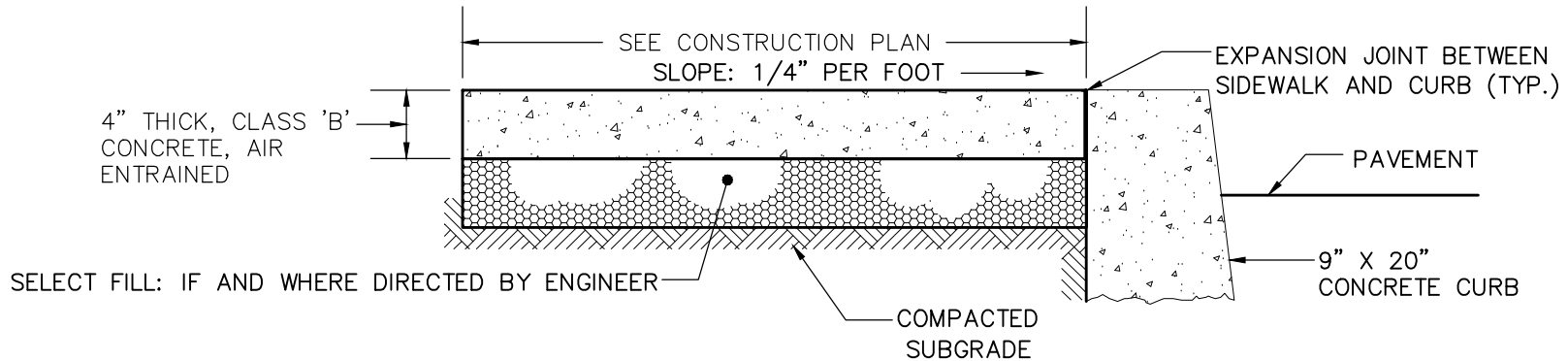

CONCRETE SIDEWALK DETAILS

N.T.S.

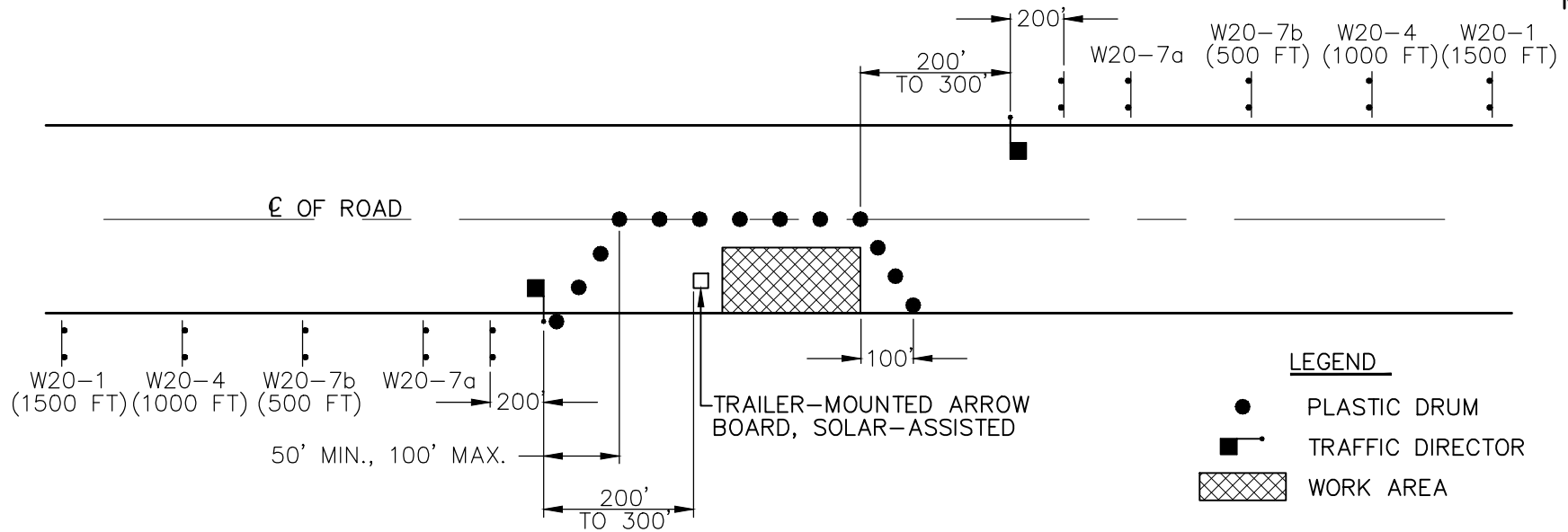

LEGEND

- PLASTIC DRUM
- TRAFFIC DIRECTOR
- ▨ WORK AREA

NOTES

1. ALL SIGNS AND OTHER TRAFFIC CONTROL DEVICES ARE TO CONFORM TO THE MANUAL ON UNIFORM TRAFFIC CONTROL DEVICES FOR STREETS AND HIGHWAYS, WHEREIN THE SIGNS IN THIS FIGURE ARE IDENTIFIED.
2. FLASHING WARNING LIGHTS ARE **NOT** TO BE MOUNTED ON ANY SIGNS.
3. FOR DAYTIME OPERATIONS OF A SHORT DURATION, AND ON ROADS THAT ARE NOT MAJOR ARTERIES, THE W20-1 (AHEAD), W20-7a AND W20-7b SIGNS WILL SUFFICE FOR EACH APPROACH. THE TRAFFIC DIRECTOR AND ALL OTHER DEVICES REMAIN THE SAME.
4. DRUMS ARE TO BE PLACED AT 30' INTERVALS THROUGHOUT THE WORK ZONE.
5. TRAFFIC DIRECTORS SHALL USE STOP/SLOW PADDLES (R1-1) AND, WHERE SIGHT IS OBSTRUCTED, WALKIE-TALKIES.

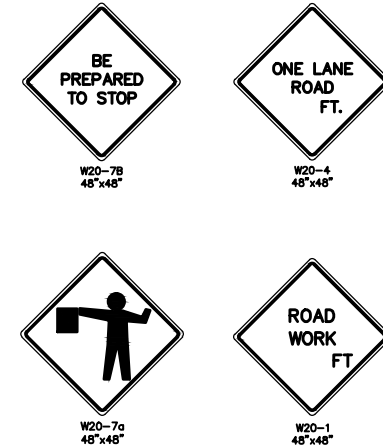

TYPICAL ONE-LANE-CLOSURE OPERATION

N.T.S.

SOMERSET COUNTY SIGNAGE & STRIPING NOTES

1. The Somerset County Traffic Division is to be notified at (909) 231-7162 a minimum of 72 hours prior to the installation of any striping within a County right-of-way. The notification is to be made by the contractor who will install the striping.
2. Prior to installing any striping in the County right-of-way the striping contractor must receive approval from the County Traffic Division for the “Mark Out” of all striping.
3. All pavement markings shall be alkyd-type thermoplastic with a thickness of 90 mils.
4. There shall be a 6-inch space between all double yellow stripes.
5. All existing striping and pavement reflectors that do not conform to the proposed striping pattern are to be removed by a method that does not damage the roadway surface. “Black Out” paint will not be permitted.
6. All permanent signs shall be a flat aluminum sheet of 6061-T6 alloy with a thickness that shall conform to subsection 911.01.02A of the New Jersey Department of Transportation Standard Specifications of 2007.
7. All permanent signs are to be mounted on galvanized square tube steel supports of the “Telespar System” by the Unistrut Corporation and only Type III Breakaway units shall be used or equal as approved by the County Engineer.
8. All “Stop” signs (R1-1) are to be a minimum 30-inch diameter.
9. The street name sign is to be located on the opposite corner from the “Stop” sign (R1-1).
10. Sign facings shall be “Wide Angle Prismatic Retroreflective Sheeting for Visual Impact Performance” manufactured by 3M Brand Scotchlite Prismatic Lens Reflective Sheeting (Diamond Grade³) or equal as approved by the County Engineer.
11. All traffic control devices shall conform to the current “Manual on Uniform Traffic Control Devices for Streets and Highways”.

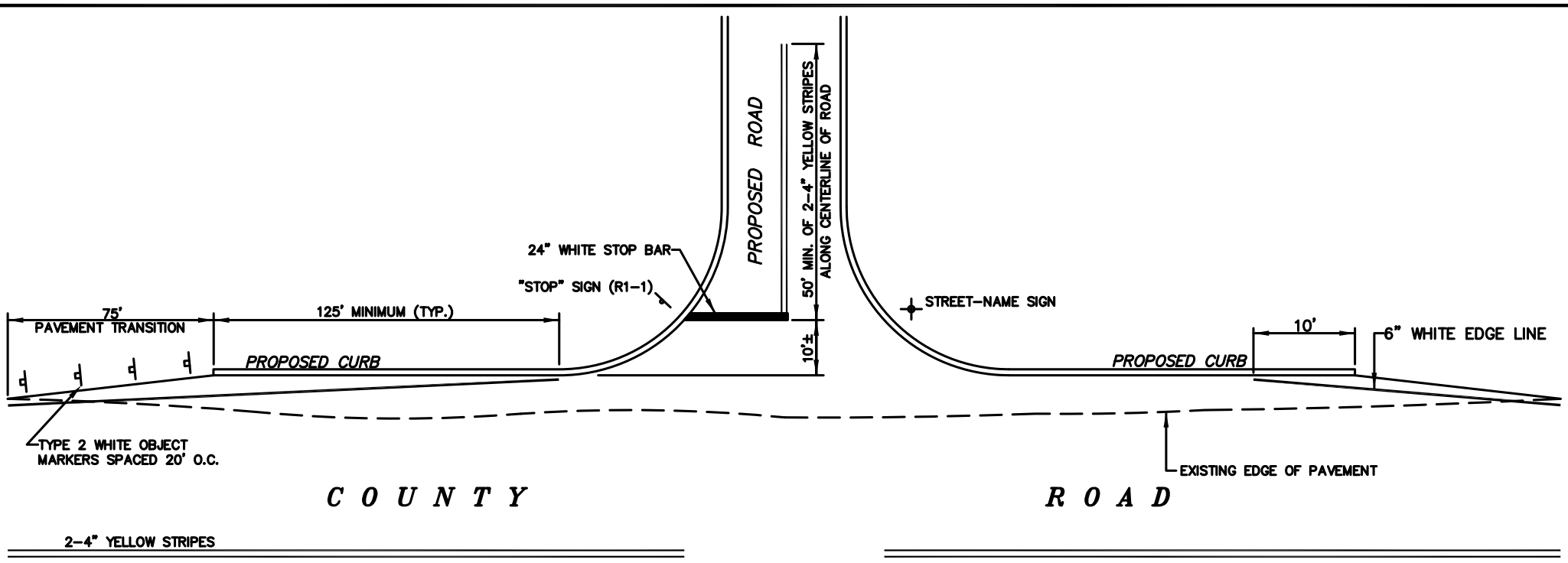

GENERAL NOTES

1. THE SOMERSET COUNTY TRAFFIC DIVISION IS TO BE NOTIFIED A MINIMUM OF 72 HOURS PRIOR TO THE INSTALLATION OF ANY STRIPING WITHIN A COUNTY R.O.W. THE NOTIFICATION IS TO BE MADE BY THE CONTRACTOR WHO WILL INSTALL THE STRIPING.
2. PRIOR TO INSTALLING ANY STRIPING IN THE COUNTY R.O.W., THE STRIPING CONTRACTOR MUST RECEIVE APPROVAL FROM THE COUNTY TRAFFIC DIVISION TO "MARK OUT" STRIPING.
3. ALL PAVEMENT MARKINGS SHALL BE ALKYD-TYPE THERMOPLASTIC WITH A THICKNESS OF 90 MILLIMETERS.
4. THERE SHALL BE 6" SPACE BETWEEN ALL DOUBLE YELLOW STRIPES.
5. ALL "STOP" SIGNS (R1-1) ARE TO BE 36" IN DIAMETER WITH A TWO-POST INSTALLATION AND ARE TO HAVE 3M BRAND DIAMOND-GRADE SHEETING.
6. ALL SIGN-SUPPORT POSTS ARE TO BE TELESAR BRAND SQUARE-TUBE STEEL THAT IS GALVANIZED AND YIELDING-TYPE III.
7. THE STREET-NAME SIGN (IF CALLED FOR ON PLAN) IS TO BE LOCATED ON THE OPPOSITE CORNER FROM THE R1-1 SIGN.
8. IF A STRIPED CROSSWALK IS TO BE INSTALLED, THE STOPBAR SHALL BE LOCATED 5' FROM THE EDGE OF THE CROSSWALK CLOSEST TO THE STOPBAR.

SIGNING AND STRIPING
FOR PROPOSED INTERSECTION

N.T.S.

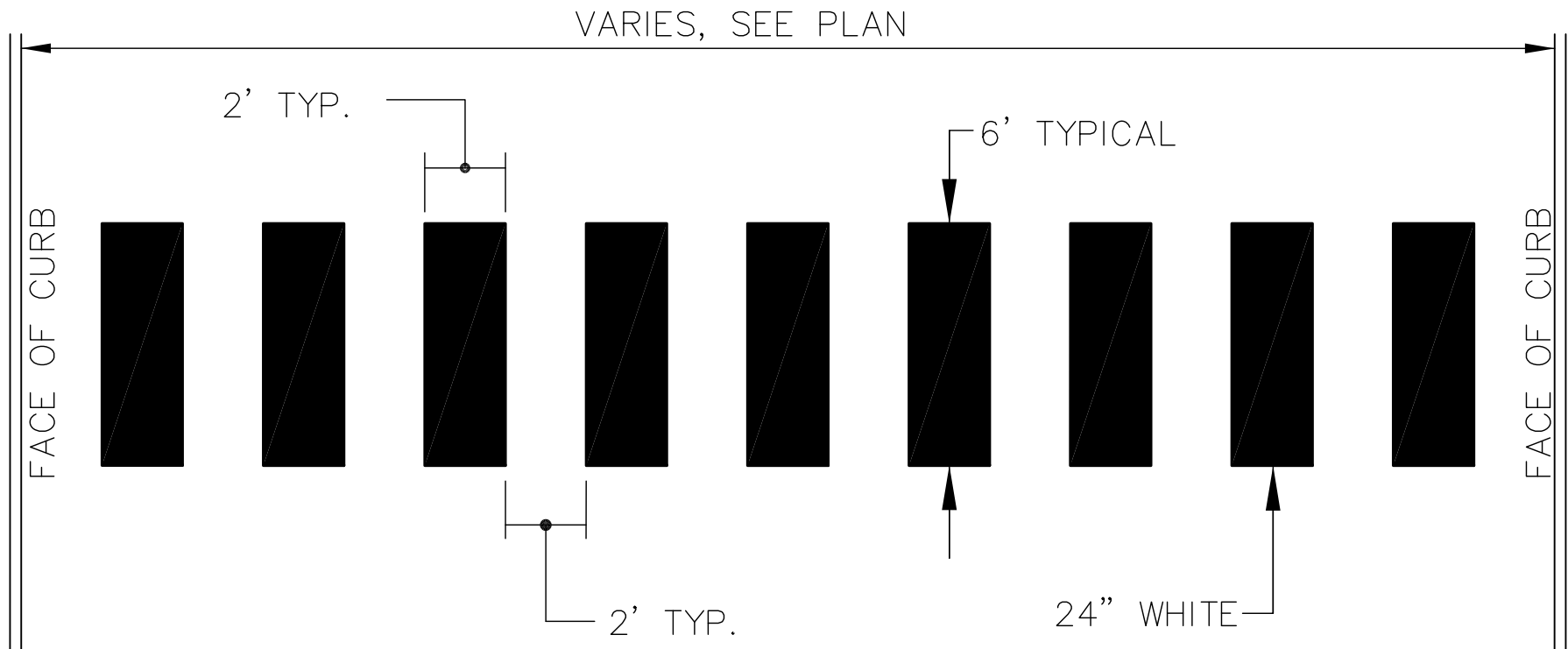

CROSSWALK STRIPING

N.T.S.

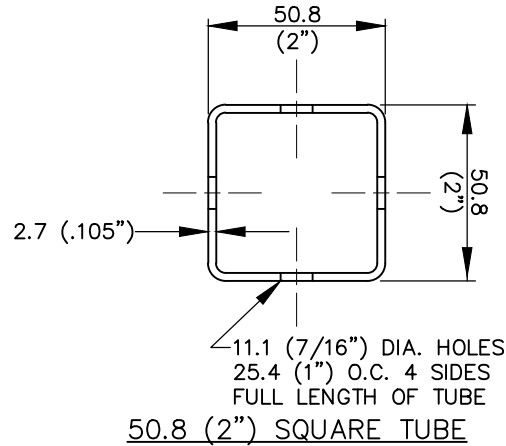
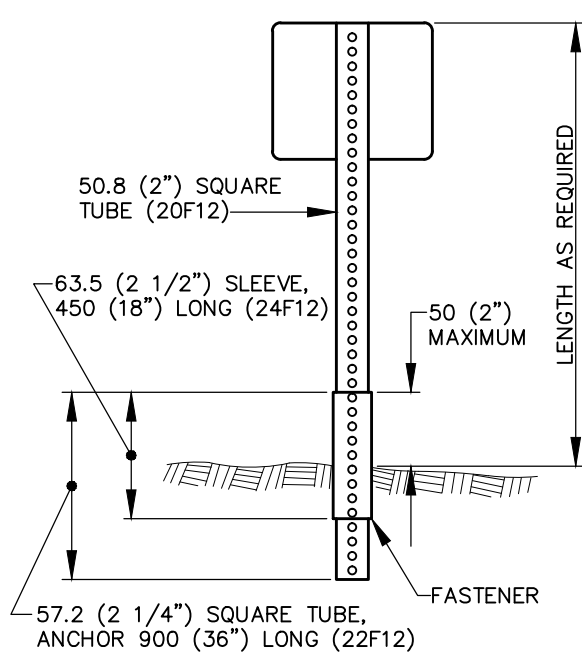

PROPERTIES OF 50.8 (2") SQUARE TUBE	
AREA	3.81 cm, .590"
WEIGHT	3.60 Kg/m, 2.416 lb./ft.
MOMENT OF INERTIA	15.48 cm, .372"
SECTION MODULUS	5.10 cm, .372"
RADIUS OF GYRATION	2.02 cm, .794"
TORSIONAL FACTOR (J)	20.81 cm, .500"

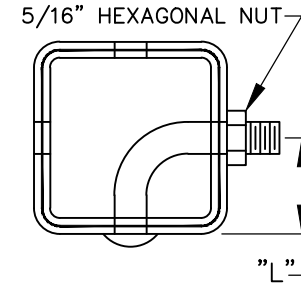

SQUARE-TUBE SIZE	"L"
1 1/2" (14F12)	31/32"
1 3/4" (16F12)	31/32"
2" (20F12)	31/32"
2 1/4" (22F12)	1 3/16"
2 1/2" (24F12)	1 3/16"

CORNER BOLT AND NUT

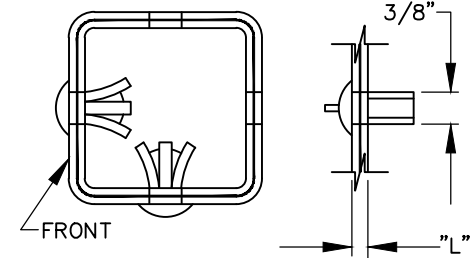

VANDAL-RESISTANT RIVET

THE CRIMP LENGTH "L" IS 3/16" OR 1/4".

GENERAL NOTES

- SQUARE-TUBE SUPPORTS ARE TO BE THE TELESPAR SYSTEM BY THE UNISTRUT CORPORATION OR AN APPROVED EQUAL, AND ONLY TYPE III BREAKAWAY UNITS SHALL BE USED.
- BOLTS SHALL CONFORM TO THE REQUIREMENTS OF ASTM A-307 AND NUTS TO A-563, GRADE A, AND SHALL BE ELECTROGALVANIZED IN ACCORDANCE WITH THE REQUIREMENTS OF ASTM B-633, TYPE III, SC 1.
- THE POSTS SHALL BE 50.8 (2") TUBES FORMED FROM 2.7 (.105") THICK STEEL CAREFULLY ROLLED TO SIZE, CORNER-WELDED BY HIGH-FREQUENCY RESISTANCE WELDING AND EXTERNALLY SCARFED TO AGREE WITH THE CORNER RADII. THE POSTS SHALL HAVE 11.1 (7/16") DIAMETER HOLES SPACED 25.4 (1") ON CENTER ALONG THE CENTER LINE OF EACH SIDE.
- THE ANCHOR TUBE SHALL BE A 57.2 (2 1/4") SQUARE TUBE, 750 (30") TO 1200 (48") LONG, INSTALLED IN SOIL 50 (2") TO 75 (3") ABOVE THE GROUND BUT NOT HIGHER THAN 100 (4"). THE UPPER SIGNPOST SHALL TELESCOPE INSIDE THE ANCHOR APPROXIMATELY 200 (8") TO 300 (12").
- A TUBE-REINFORCED SLEEVE, 63.5 (2 1/2") SQUARE AND 450 (18") LONG, SHALL BE INSTALLED OVER THE 57.2 (2 1/4") SQUARE ANCHOR AND FLUSH WITH THE TOP.
- GALVANIZED SIGNPOSTS SHALL BE ROLL FORMED FROM STEEL CONFORMING TO ASTM SPECIFICATION A-446 WITH ZINC COATING DESIGNATION G-90.

SQUARE-TUBE SUPPORT FOR PERMANENT SIGN

N.T.S.

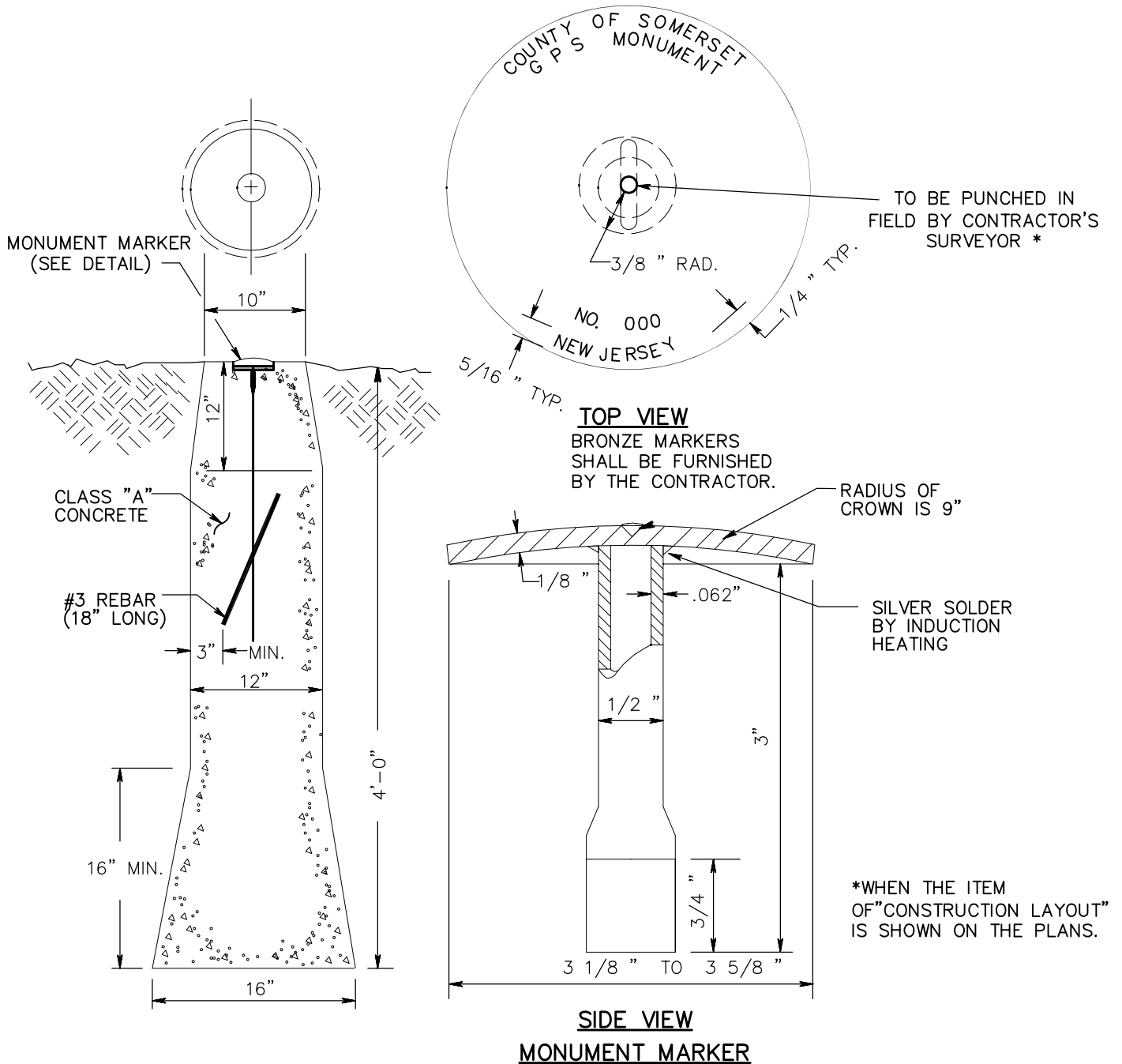

MONUMENTS TO BE SET FLUSH WITH GROUND.

THESE MONUMENTS ARE TO BE POURED IN PLACE AND THE MARKER PLUMBED INTO POSITION AND SET IN THE CONCRETE IN SUCH A MANNER THAT NO AIR WILL BE TRAPPED ON THE UNDERSIDE OF THE MARKER.

#3 REBAR, 18" LONG, TO BE PLACED AT THE TIME OF CONCRETE POUR.

MONUMENT MARKER IS TO BE MADE OF BRONZE, CONFORMING TO ASTM B-19.

G.P.S. MONUMENT

N.T.S.

Somerset County GPS Monumentation Project
SURVEYOR'S CERTIFICATION FORM

Monument No. _____ (As assigned by County Engineer's Office)
Associated Development Project: _____
Municipality: _____ Street: _____ Location: _____
Name of Surveyor: _____ Firm: _____
Address: _____
City: _____ State: _____ Zip: _____

Monument Installation & Observation Information

Date Set: _____ Set By: _____
Depth of Monument Footing: _____ Tie Sheet Provided: _____
Date of Observation: _____ Equipment Used: _____
Control Monuments (Min. of 3): 1. _____ 2. _____ 3. _____
Length of Observation: _____ Adjustment Software: _____ Rev. _____
X – Coordinate (East) _____ Datum: _____
Y- Coordinated (North) _____ Datum: _____
Elevation _____ Datum: _____ Scale Factor: _____

Certification

I hereby certify to the County of Somerset that the above referenced monument has been surveyed under my immediate supervision. All monuments set meet a minimum horizontal accuracy of +/- 2cm and a minimum vertical accuracy of +/- 3cm. Indicate type of survey below:

Conventional Surveys:

I also certify that the horizontal positional accuracy of the coordinates as shown hereon, relative to the control network, meet or exceed the Federal Standard for Second Order, Class I distance accuracy standards as outlined in the Federal Geodetic Control Committee publication entitled "*Standards and Specifications for Geodetic Control Networks*" dated September 1984.

Opus Positions:

GPS Positions have been derived through OPUS and meet the 4 hour minimum collection time for submission, observed two times, a minimum of 4 hours apart. Copies of all output reports are attached.

Opus R-S Positions:

GPS Positions have been derived through OPUS and meet a 20 minute minimum collection time for submission, observed two times, a minimum of 4 hours apart. Copies of all output reports are attached.

Signature and Seal of NJ Licensed Land Surveyor Lic. No. Date

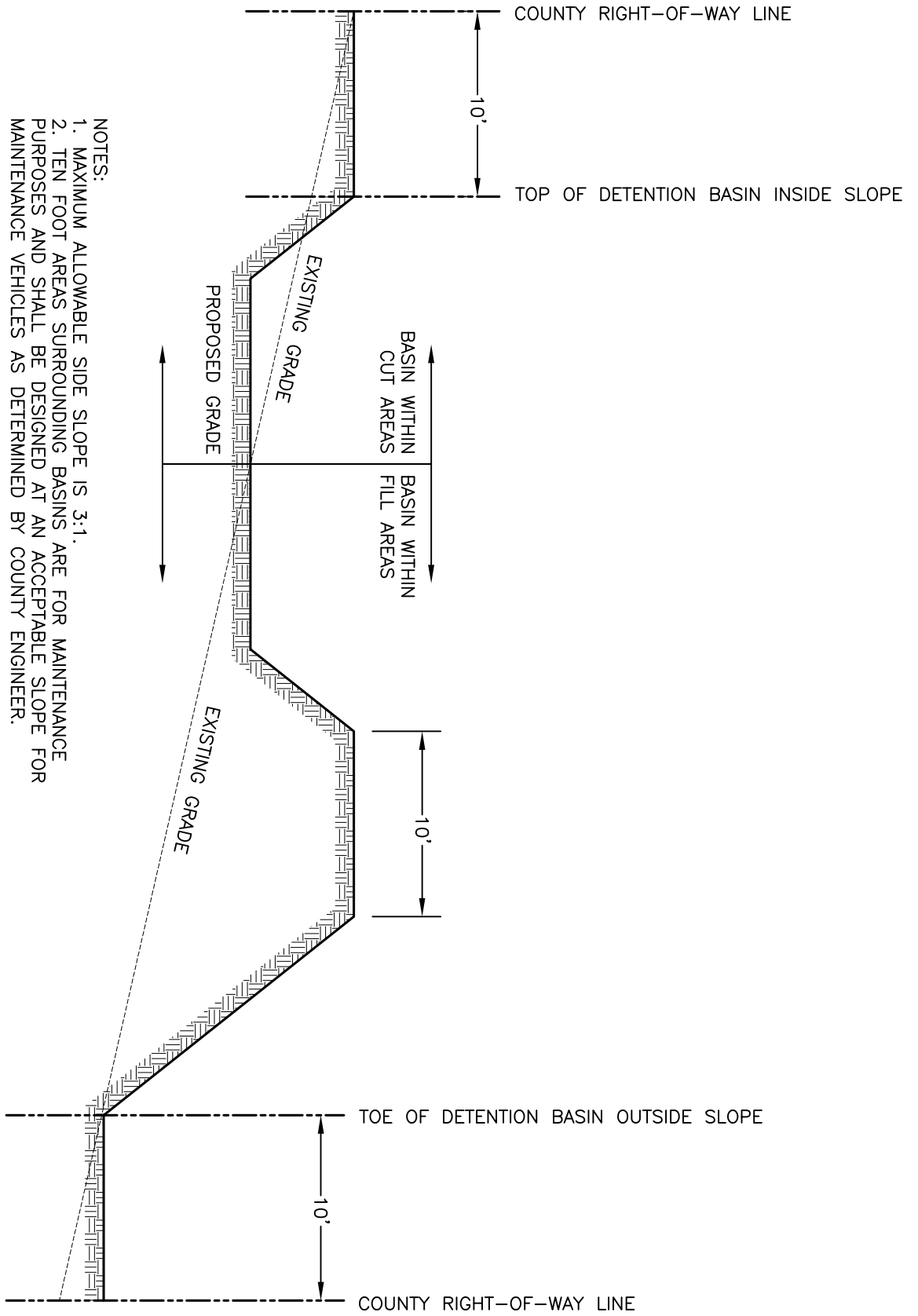

- NOTES:
1. MAXIMUM ALLOWABLE SIDE SLOPE IS 3:1.
 2. TEN FOOT AREAS SURROUNDING BASINS ARE FOR MAINTENANCE PURPOSES AND SHALL BE DESIGNED AT AN ACCEPTABLE SLOPE FOR MAINTENANCE VEHICLES AS DETERMINED BY COUNTY ENGINEER.

STORMWATER DETENTION/RETENTION SETBACK
 REQUIREMENTS FROM COUNTY FACILITIES
 NOT TO SCALE

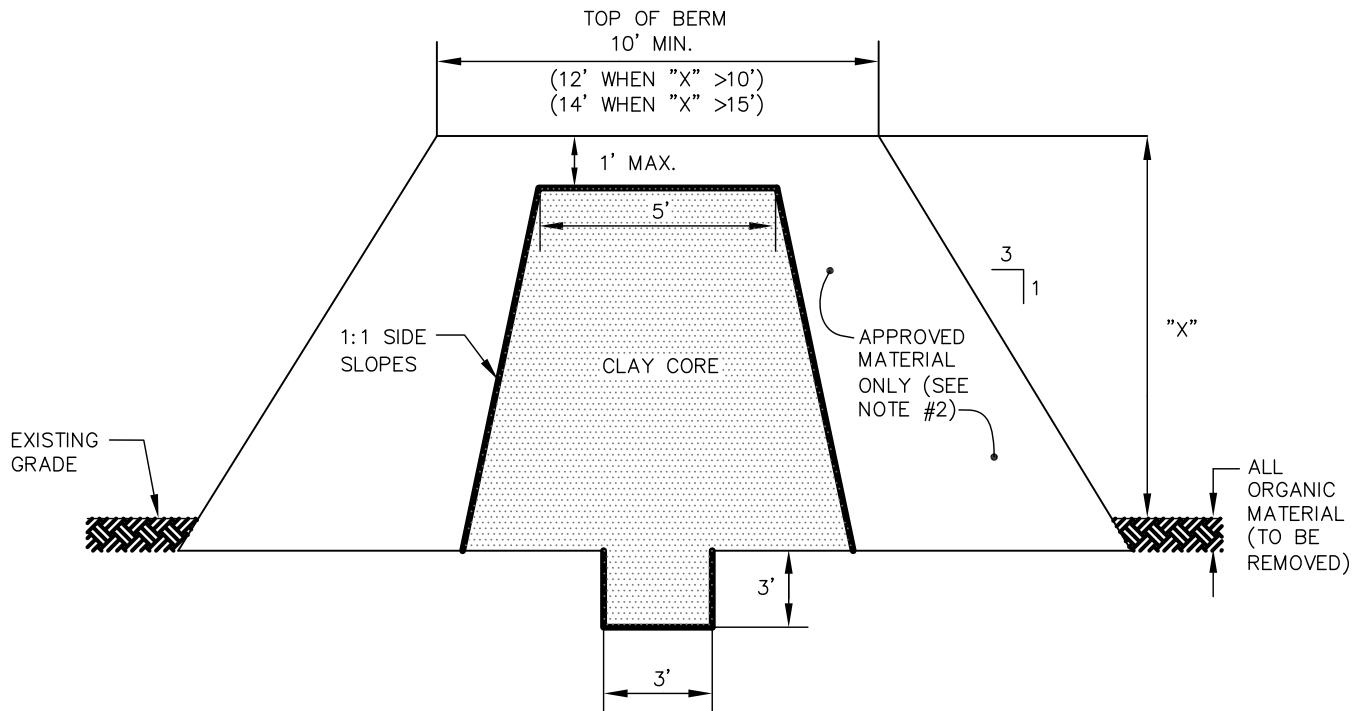

NOTES:

1. THE CLAY CORE SHALL CONSIST OF COMPACTED CLAY MATERIAL (UNIFIED SOIL CLASSIFICATION "CL").
2. THE FILL MATERIAL IN ALL EARTH DAMS AND EMBANKMENTS SHALL BE COMPACTED TO AT LEAST 95% OF THE MAXIMUM DENSITY OBTAINED FROM COMPACTION TESTS PERFORMED BY THE APPROPRIATE METHOD IN ASTM D698.
3. TREES AND OTHER VEGETATION WITH LARGE EXTENSIVE ROOT STRUCTURE SHALL NOT BE PERMITTED ON ANY DAM OR EMBANKMENT.
4. THE BASIN IS TO BE TOPSOILED WITH A MINIMUM OF 4" OF TOPSOIL AND SEEDDED, INCLUDING THE BOTTOM, SIDE SLOPES AND ALL EARTHEN DAMS AND EMBANKMENTS. "TOPSOIL" IS DEFINED AS THE NATURAL, UNDISTURBED SURFACE LAYER OF SOIL HAVING MORE ORGANIC MATTER THAN SUBSEQUENT LAYERS SUITABLE FOR SATISFACTORY GROWTH AND MAINTENANCE OF PERMANENT, LOCALLY ADAPTED VEGETATION. THE MATERIAL MUST BE FRIABLE, LOAMY SOIL REASONABLY FREE OF DEBRIS, OBJECTIONABLE WEEDS, LUMPS, ROOTS, STONES, OR SIMILAR OBJECTS LARGER THAN 2-INCHES IN ANY DIMENSION; HAVE A NATURAL pH OF 5.0 TO 7.5; HAVE AN ORGANIC MATTER CONTENT GREATER THAN 2.00 PERCENT; AND CONTAIN NO TOXIC SUBSTANCES WHICH MAY BE HARMFUL TO PLANT GROWTH. THE SEEDING SHALL, AS A MINIMUM, CONFORM TO TYPE "A" GRASS SEED MIXTURE AS DEFINED IN THE NJDOT STANDARD SPECIFICATIONS FOR ROAD AND BRIDGE CONSTRUCTION.

EMBANKMENT AND DETENTION BASIN CLAY CORE

N.T.S.

(TO BE USED ON ALL EMBANKMENT AREA'S WITH FILL GREATER THAN 2')

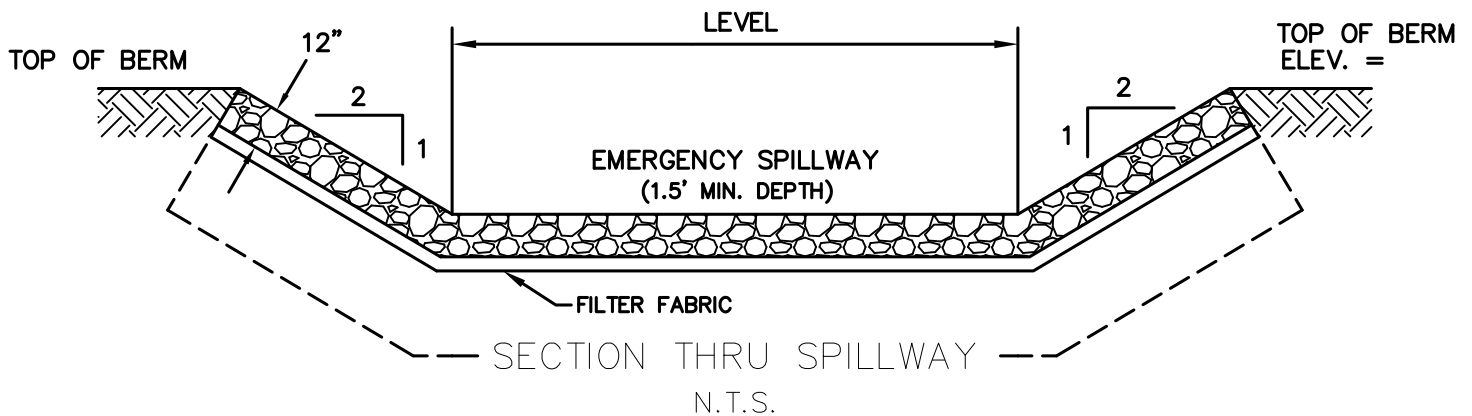
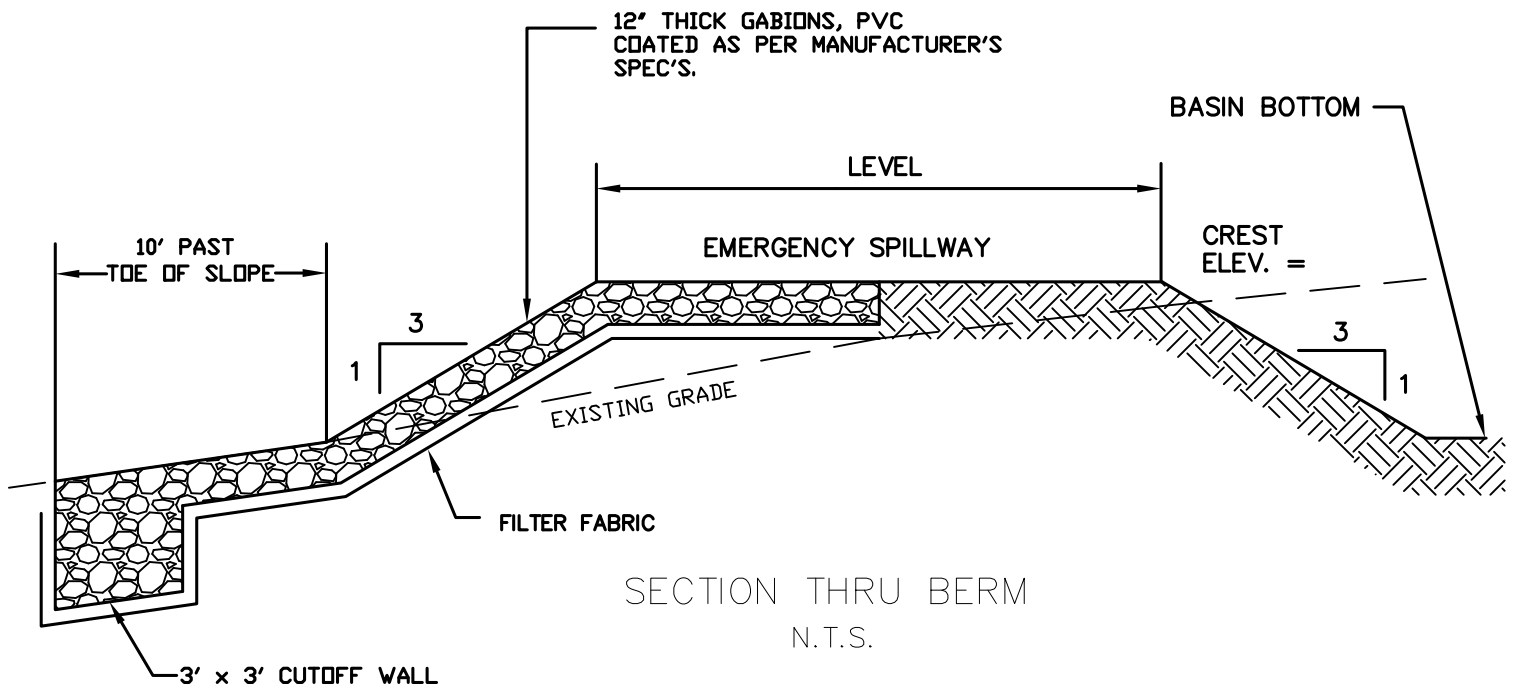

NOTES:

1. GABIONS REQUIRED IN AREAS WITH 2 FEET OR MORE OF FILL.
2. EMERGENCY SPILLWAY SHALL HAVE A MINIMUM DEPTH OF 1.5'.

STABILIZED EMERGENCY SPILLWAY

N.T.S.

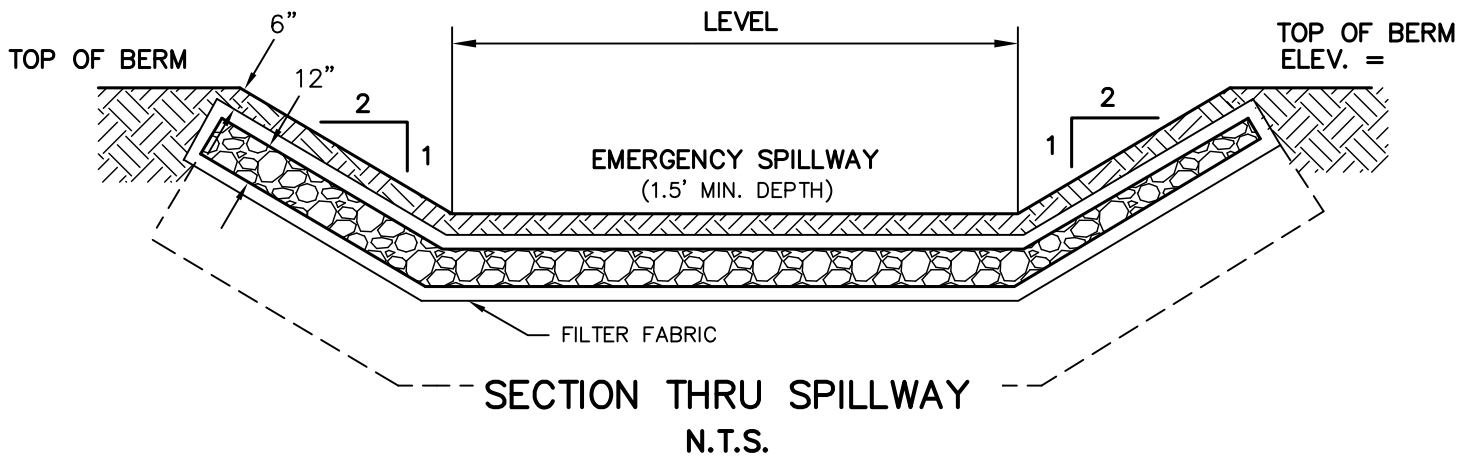
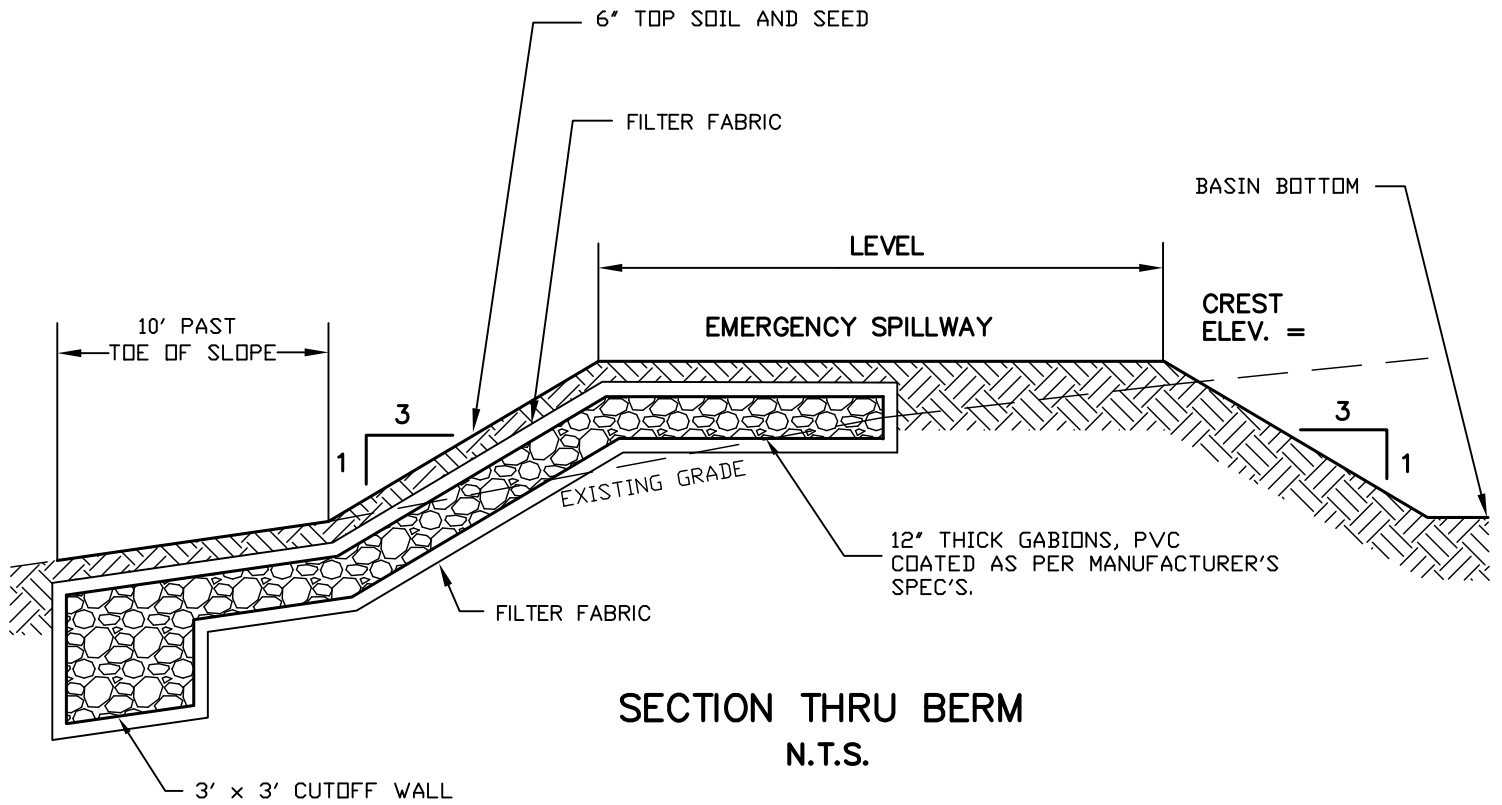

STABILIZED EMERGENCY SPILLWAY WITH GRASS COVER

N.T.S.

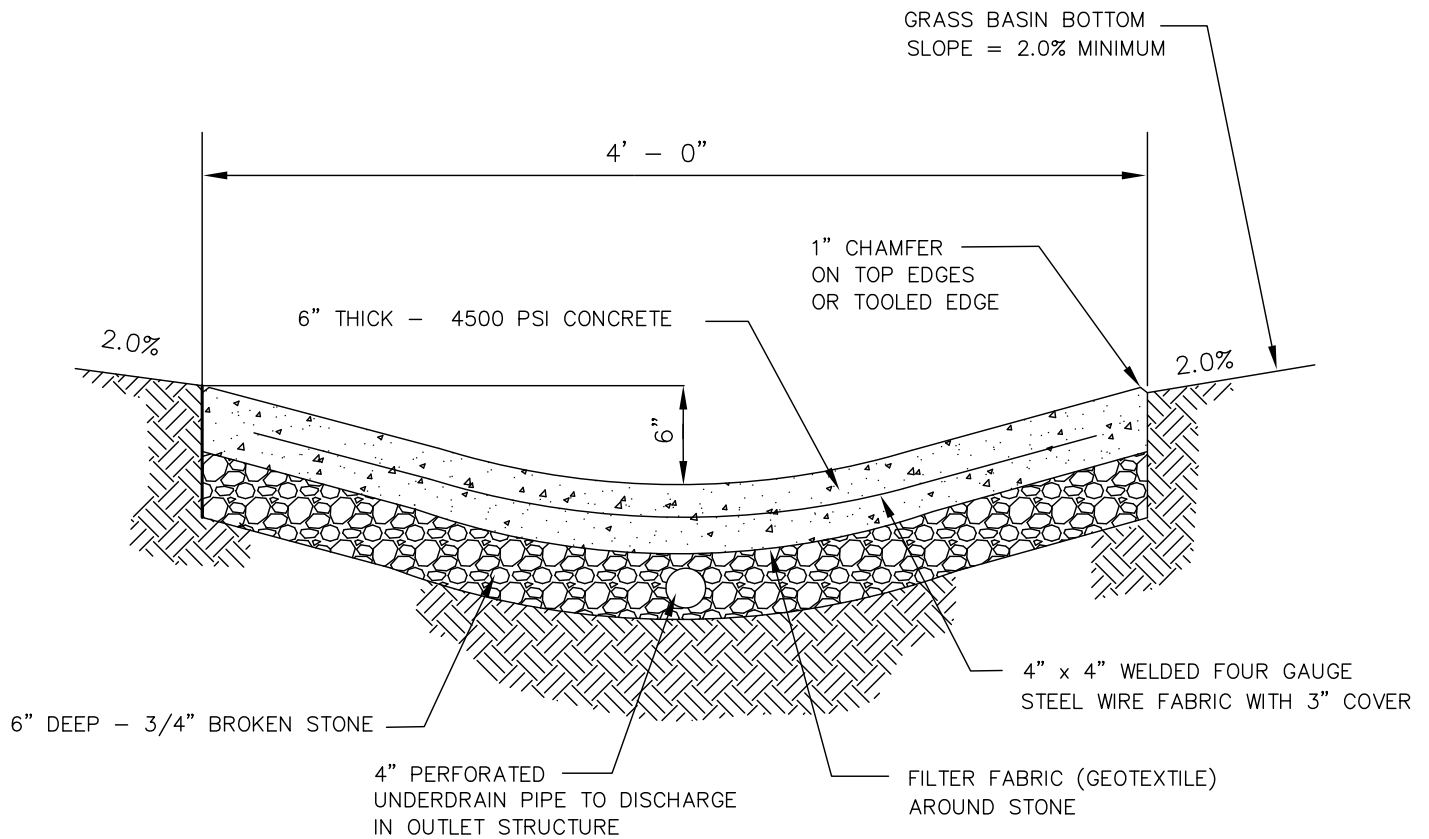

NOTES:

1. GABION LINERS ARE REQUIRED AT INFLOW PIPES WHEN THE INFLOW PIPE DIA. IS 24" OR GREATER (SEE DETAIL).
2. PROVIDE EXPANSION JOINTS WITH TOOLED EDGES IN CONCRETE AT 20' INTERVALS. EXPANSION JOINTS SHALL BE FILLED WITH PREFORMED BITUMINOUS IMPREGNATED FIBER JOINT FILLER.
3. MINIMUM SLOPE FOR CONCRETE LOW-FLOW CHANNEL = 1%.

CONCRETE LOW FLOW CHANNEL DETAIL

N.T.S.

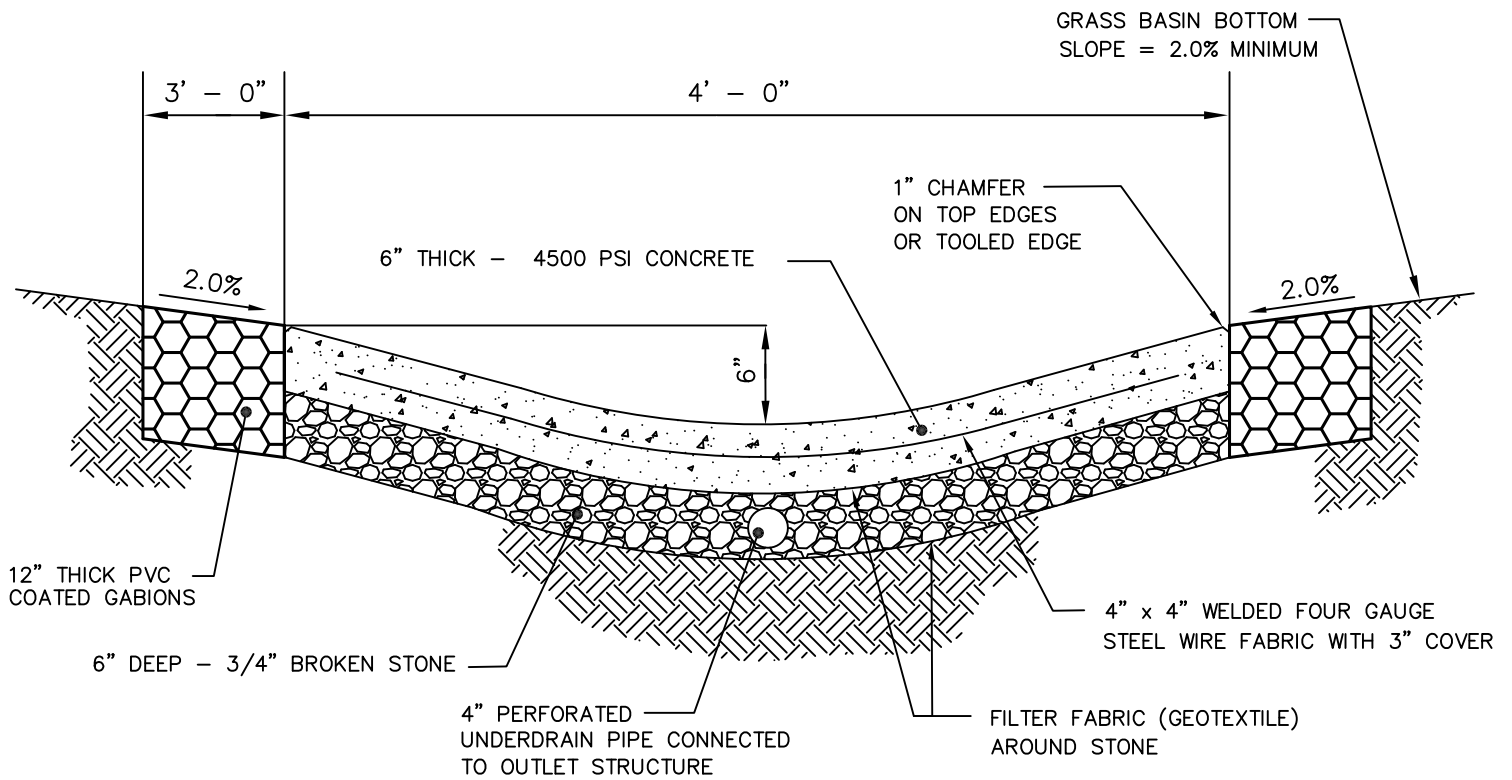

NOTES:

1. GABIONS ARE REQUIRED WHEN THE INFLOW PIPE DIA. IS 24" OR GREATER.
2. PROVIDE EXPANSION JOINTS WITH TOOLED EDGES IN CONCRETE AT 20' INTERVALS. EXPANSION JOINTS SHALL BE FILLED WITH PREFORMED BITUMINOUS IMPREGNATED FIBER JOINT FILLER.
3. MINIMUM SLOPE FOR CONCRETE LOW-FLOW CHANNEL = 1%.

LOW-FLOW CHANNEL LINING DETAIL
FOR INFLOW PIPES GREATER THAN 18"

N.T.S.

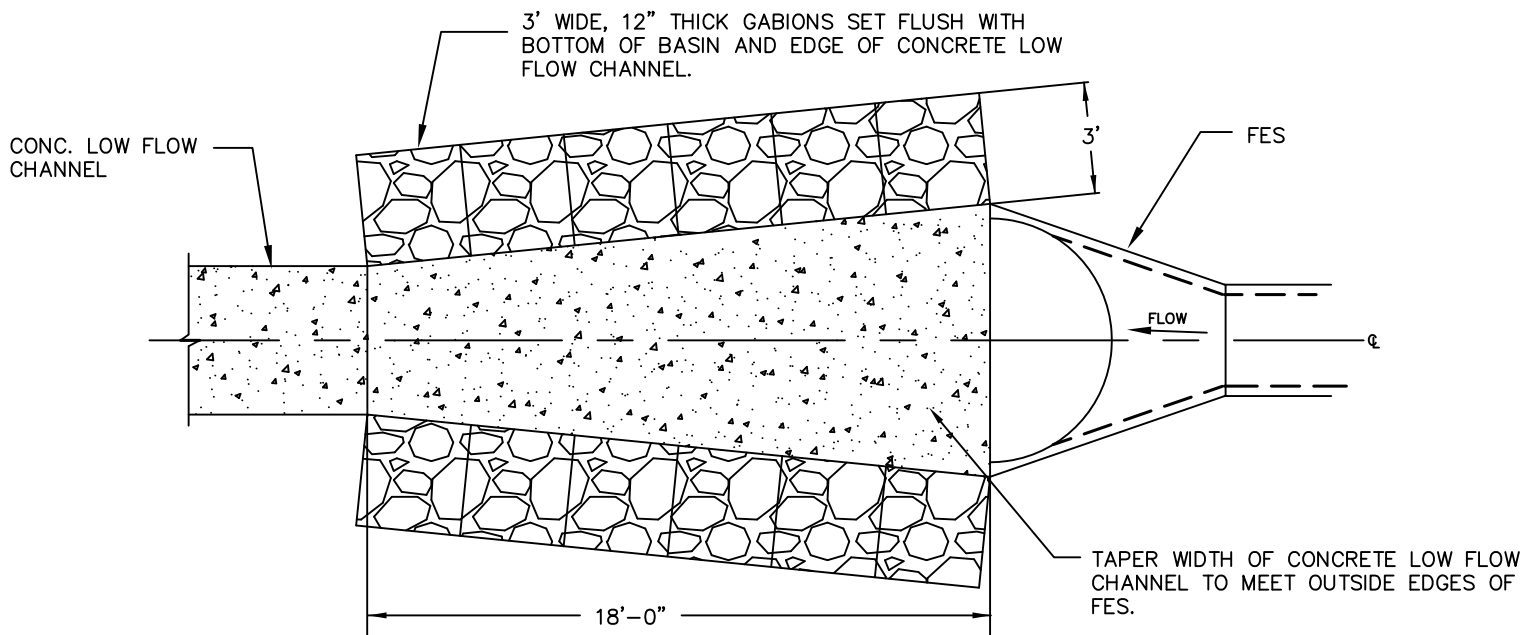

TRANSITION BETWEEN FES AND
LOW FLOW CHANNEL

N.T.S.

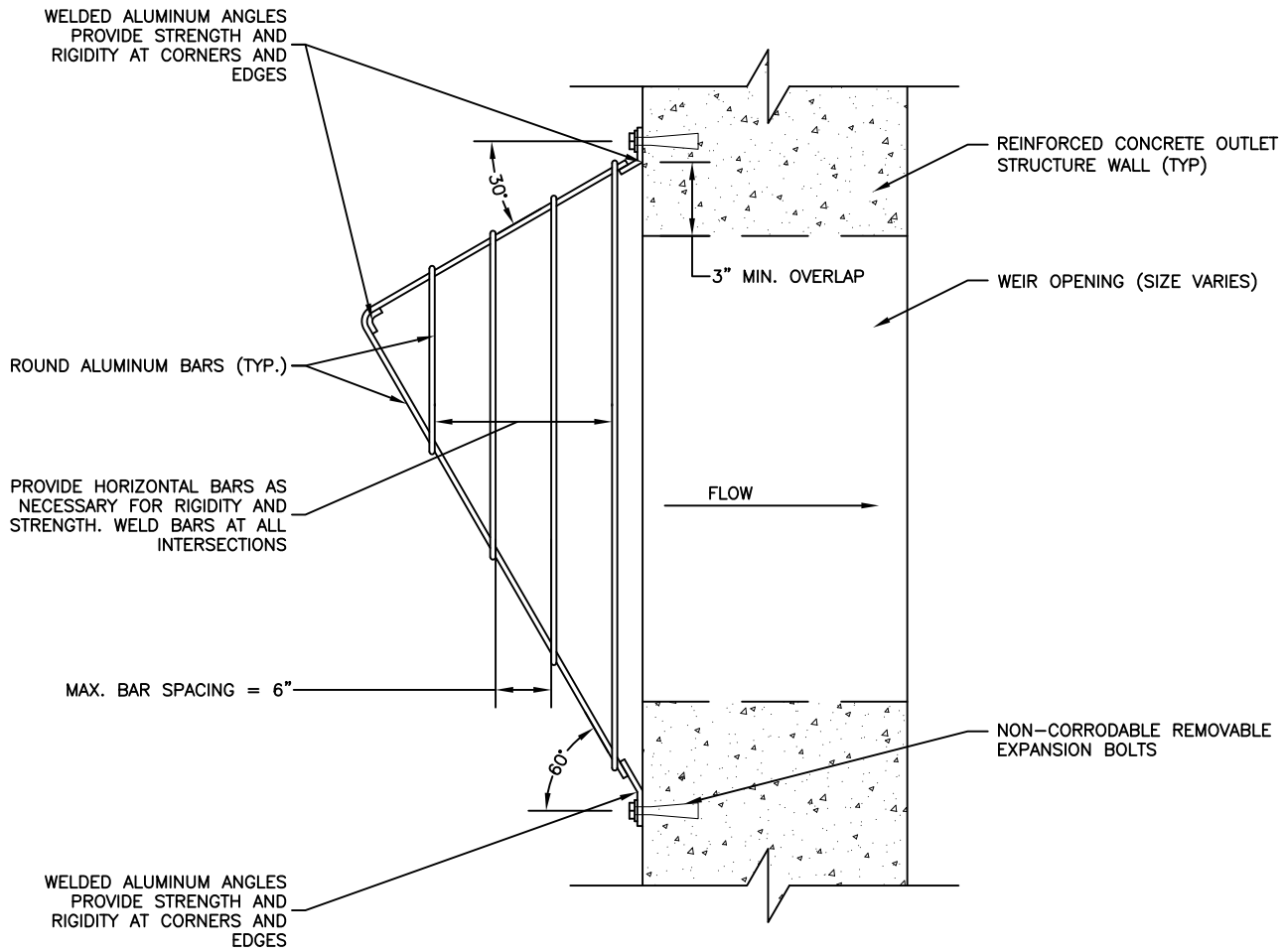

NOTES:

1. ALL TRASH RACKS MUST HAVE SUFFICIENT NET OPEN AREA PERPENDICULAR TO FLOW TO CONVEY PEAK DESIGN FLOW THROUGH THEM WITH MAXIMUM VELOCITY OF 2 FPS IN MOST CASES. PEAK DESIGN FLOW SHOULD BE BASED UPON PASSAGE OF EMERGENCY SPILLWAY HYDROGRAPH.
2. ALL ALUMINUM SURFACES MOUNTED DIRECTLY TO CONCRETE MUST BE PAINTED WITH A HEAVY COAT OF ALUMINUM PIGMENTED ALKALINE RESISTANT BITUMINOUS PAINT EQUAL TO MILITARY SPECIFICATION 'MIL-P-6883'.
3. ALL TRASH RACKS AND FASTENERS MUST HAVE SUFFICIENT STRENGTH TO WITHSTAND ANTICIPATED LOADS.

SECONDARY WEIR TRASH RACK DETAIL

NOT TO SCALE

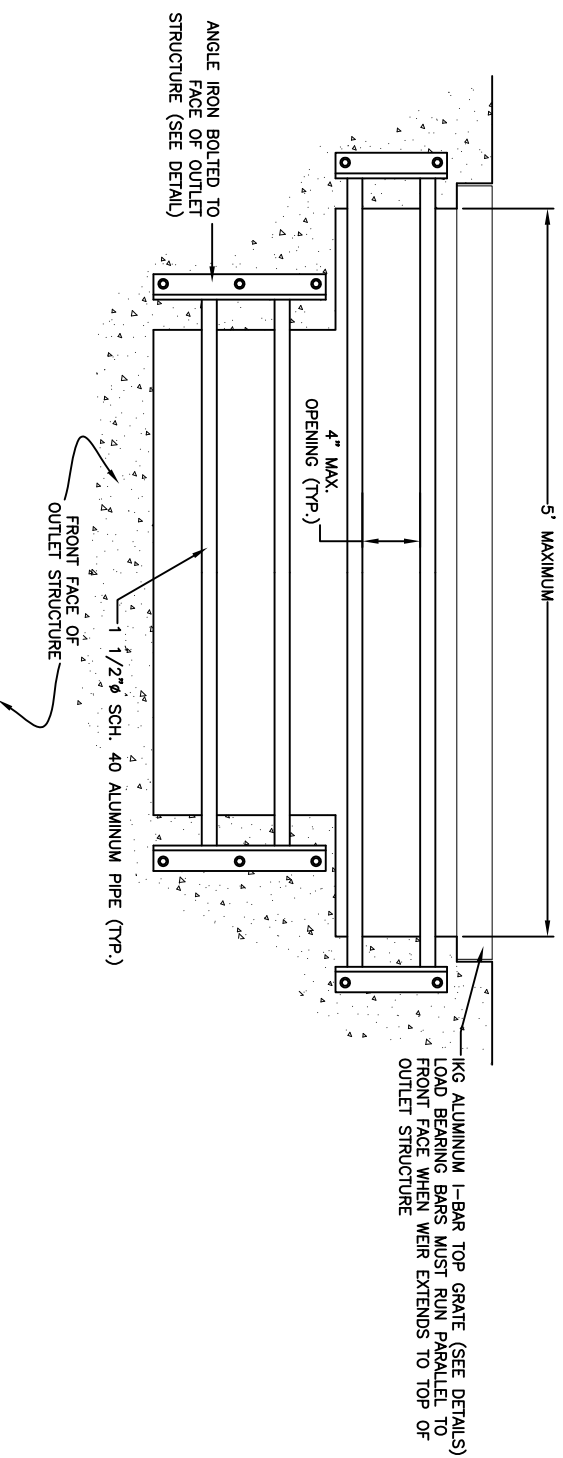
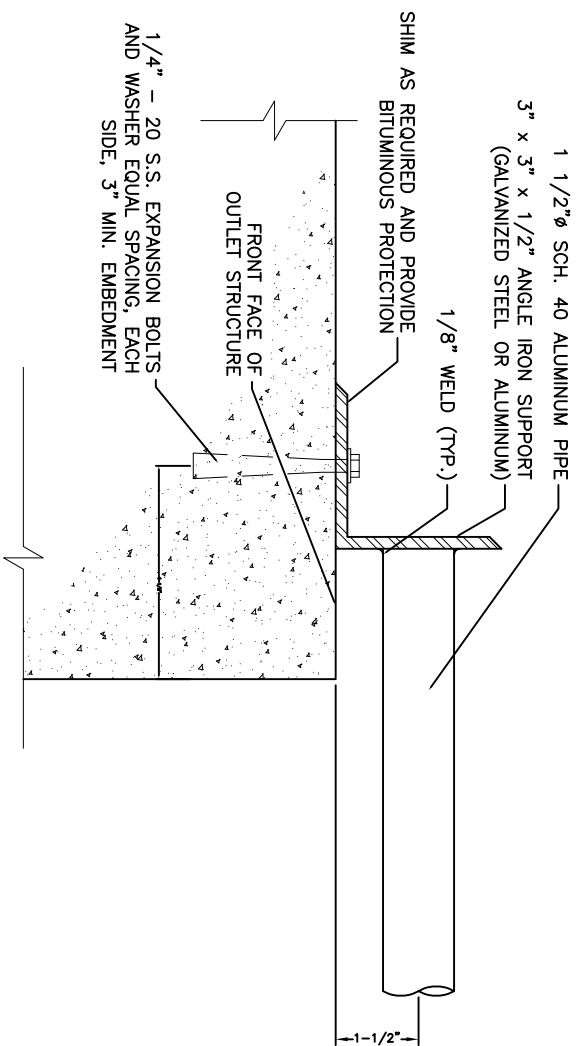

SECONDARY WEIR SAFETY/TRASH RACK

N.T.S.

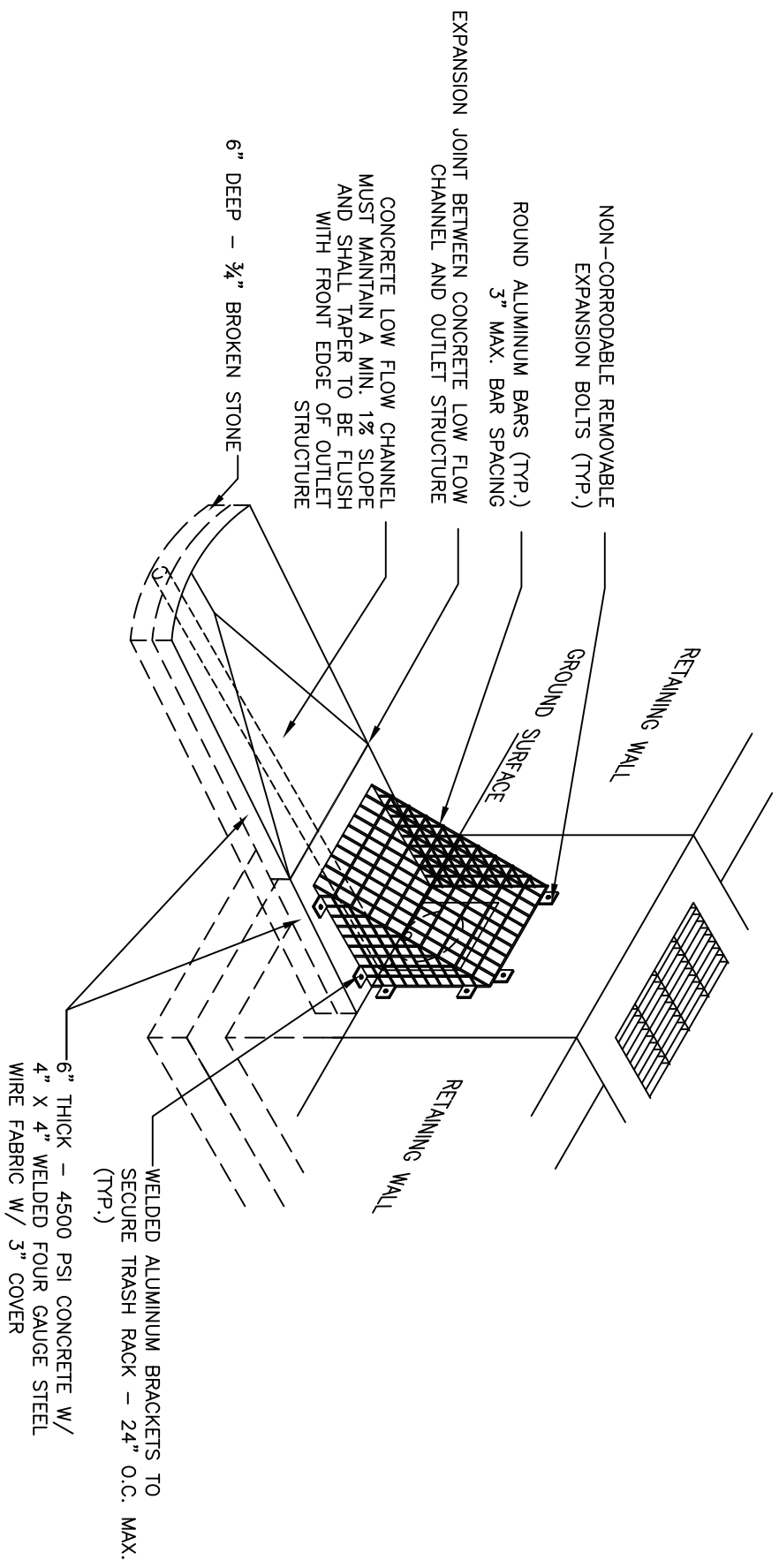

ORIFICE TRASH RACK FOR BASINS WITH RETAINING WALL

N.T.S.

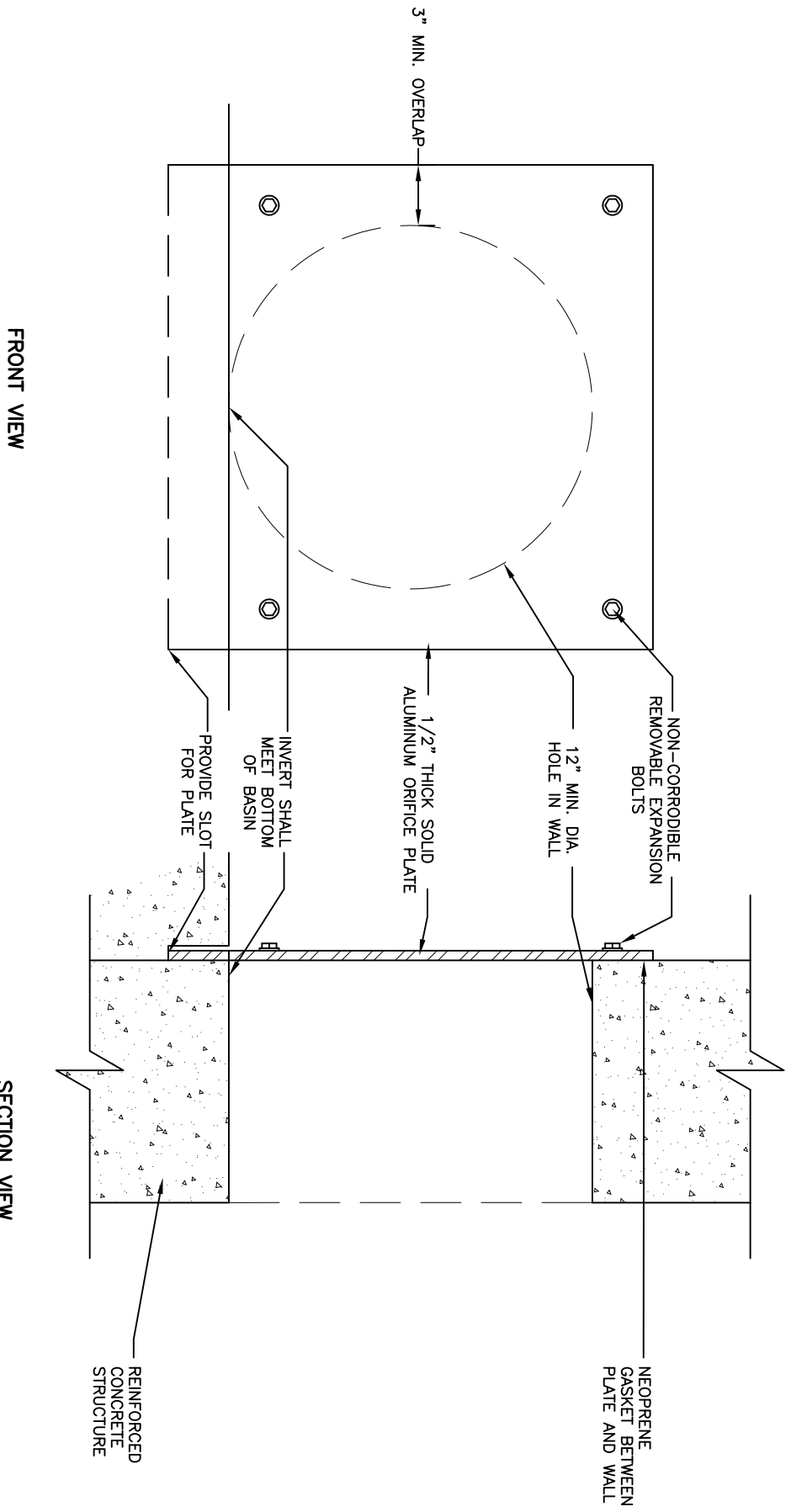

ORIFICE PLATE

NOT TO SCALE

COUNTY OUTLET STRUCTURE

N.T.S.

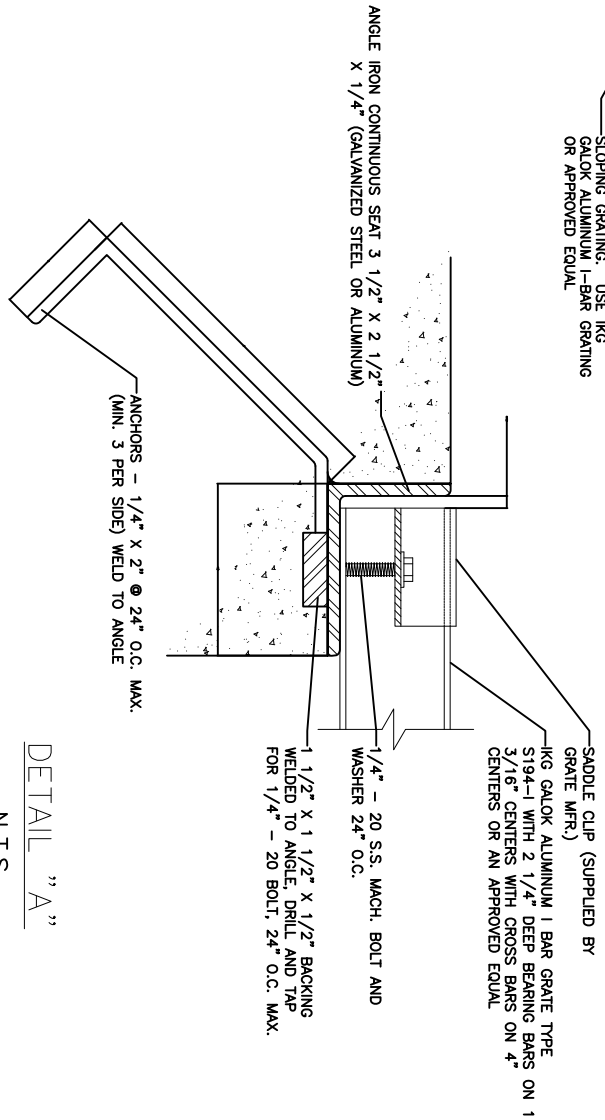
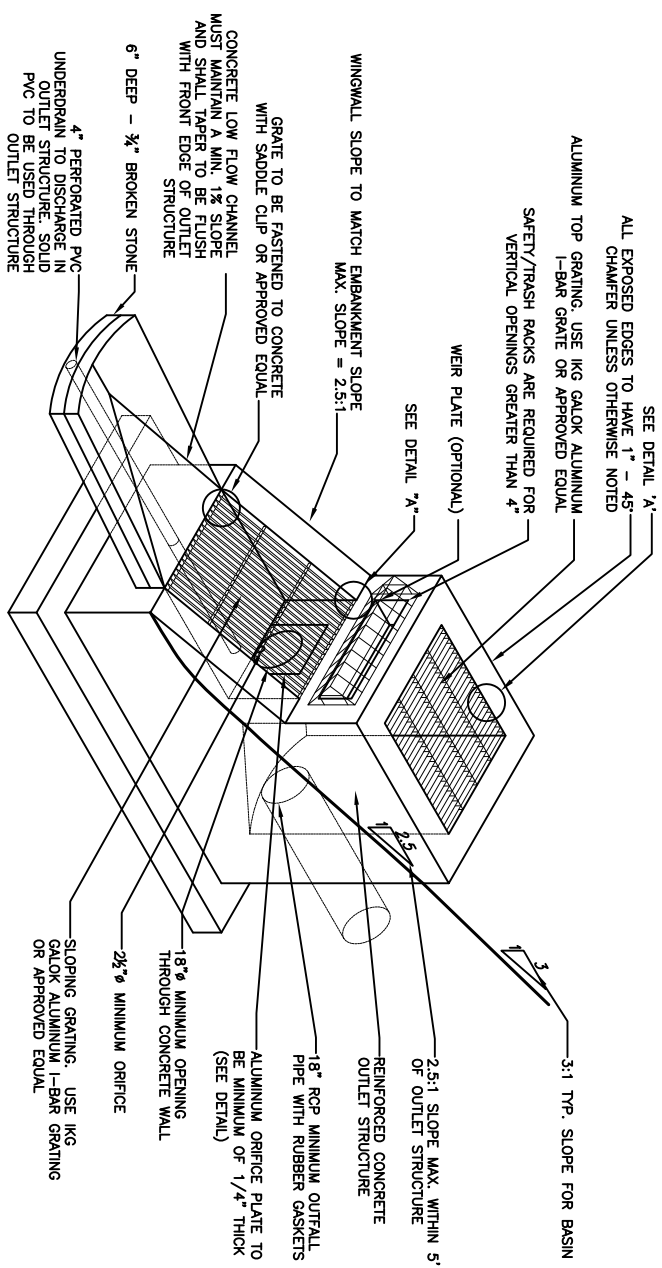

DETAIL "A"

N.T.S.

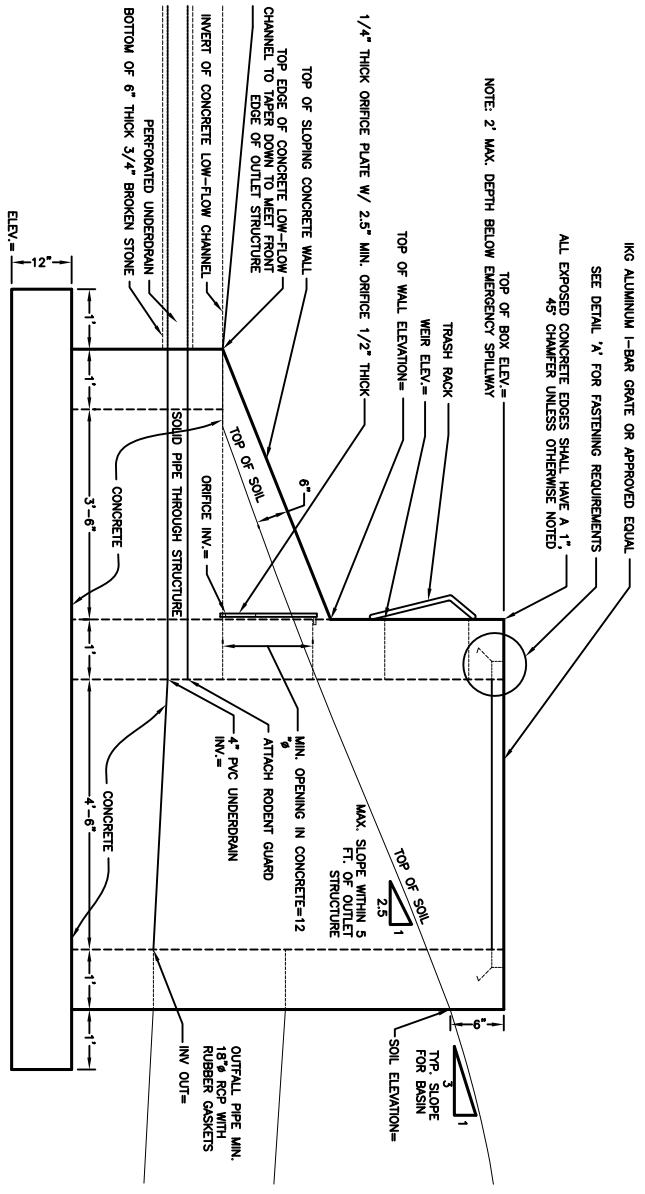

ING ALUMINUM I-BAR GRATE OR APPROVED EQUAL
 SEE DETAIL 'A' FOR FASTENING REQUIREMENTS
 ALL EXPOSED CONCRETE EDGES SHALL HAVE A 1" 45 CHAMFER UNLESS OTHERWISE NOTED

NOTE: 2' MAX. DEPTH BELOW EMERGENCY SPILLWAY

1/4" THICK ORIFICE PLATE W/ 2.5" MIN. ORIFICE 1/2" THICK

TOP OF SLOPING CONCRETE WALL
 TOP EDGE OF CONCRETE LOW-FLOW CHANNEL TO TAPER DOWN TO MEET FRONT EDGE OF OUTLET

INVERT OF CONCRETE LOW-FLOW CHANNEL

PERFORATED UNDERDRAIN
 BOTTOM OF 6" THICK 3/4" BROKEN STONE

TRASH RACK
 WEIR ELEV. =
 TOP OF WALL ELEVATION =

6" ORIFICE
 TOP OF SOIL
 ORIFICE INV. =

MIN. OPENING IN CONCRETE = 1/8"
 ATTACH RODENT GUARD
 4" PVC UNDERDRAIN
 INV. =

MAX. SLOPE WITHIN 5 FT. OF OUTLET STRUCTURE = 2.5/1

TOP OF SOIL
 TYP. SLOPE FOR BASIN = 3/1
 SOIL ELEVATION =

OUTFALL PIPE MIN. 18" RCP WITH RUBBER GASKETS
 INV. OUT =

ELEV. =

COUNTY OUTLET STRUCTURE SIDE VIEW

N.T.S.

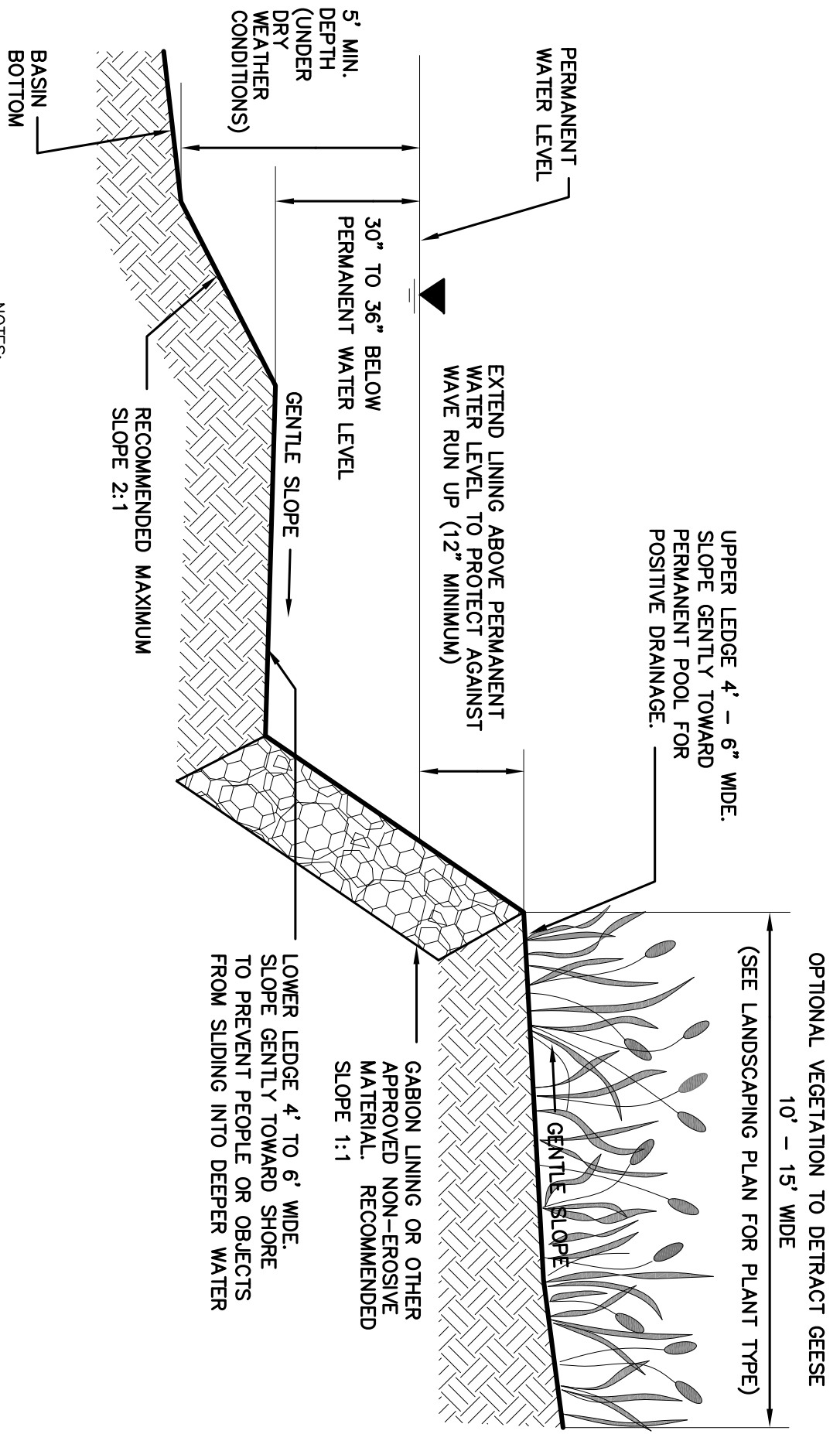

NOTES:

1. A RETENTION BASIN WITH A PERMANENT POOL SHALL HAVE A GATE VALVE DRAIN THAT IS READILY ACCESSIBLE FROM THE TOP OF THE OUTLET STRUCTURE TO PERMIT COMPLETE EMPTYING OF THE BASIN FOR MAINTENANCE, EMERGENCY, OR OTHER PURPOSES.
2. IF THE SOIL AT THE SITE IS NOT SUFFICIENTLY IMPERMEABLE TO PREVENT EXCESSIVE SEEPAGE, AN IMPERMEABLE LINER SHOULD BE INSTALLED TO MAINTAIN A PERMANENT POOL.
3. ALL RETENTION BASINS ARE TO HAVE AERATION SYSTEMS TO PROVIDE OXYGEN. SEE DETAIL.

RETENTION BASIN SIDE SLOPES

N.T.S.